

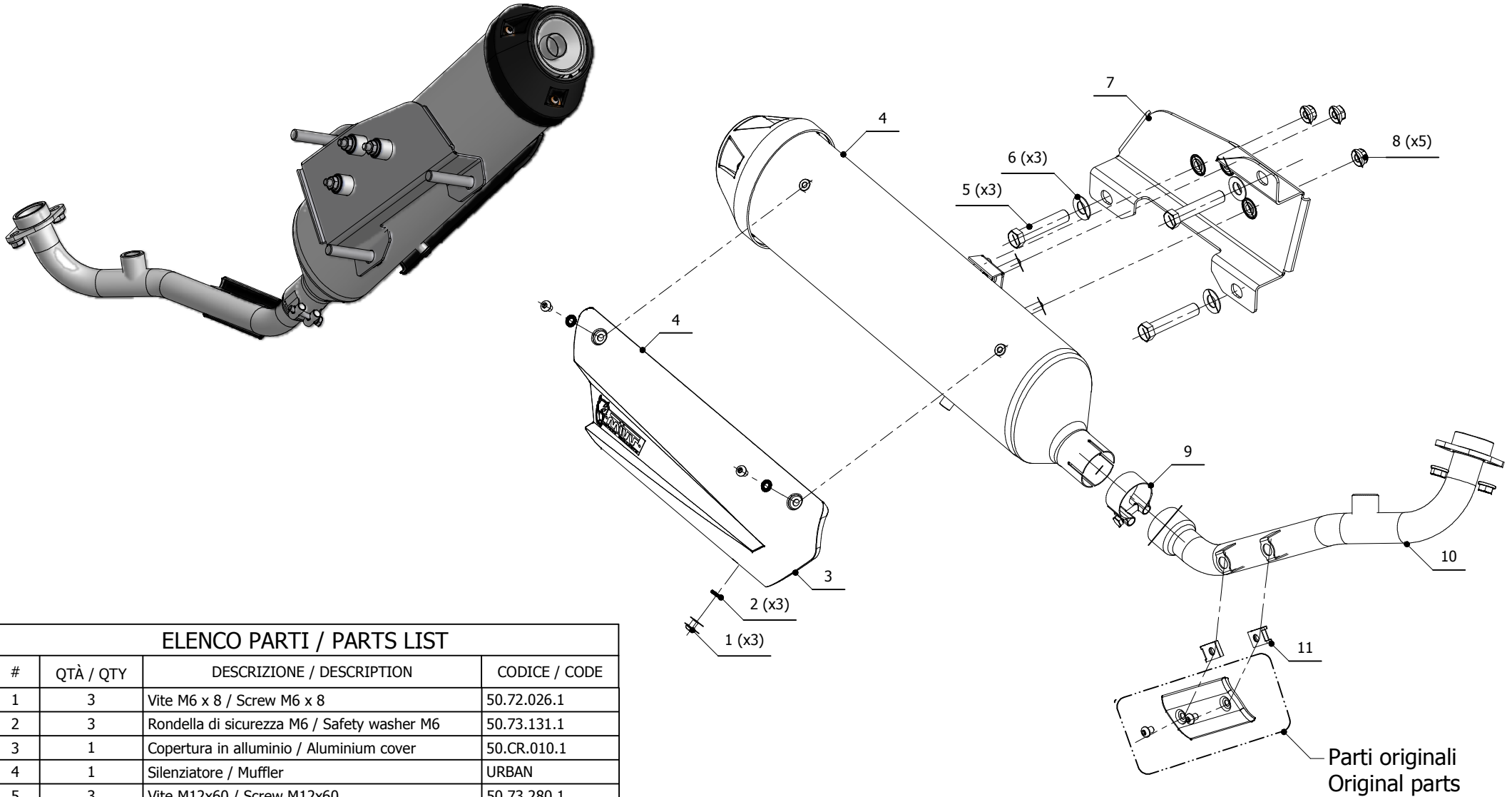

MODEL	Yamaha X-Max 250	06-	Mbk Kilibre 300	2003
	Yamaha X-City 250	07-		
	Yamaha Versity 300	03-05		

LINE	URBAN	SCHEMATIC
------	-------	-----------



**ELENCO PARTI / PARTS LIST**

#	QTÀ / QTY	DESCRIZIONE / DESCRIPTION	CODICE / CODE
1	3	Vite M6 x 8 / Screw M6 x 8	50.72.026.1
2	3	Rondella di sicurezza M6 / Safety washer M6	50.73.131.1
3	1	Copertura in alluminio / Aluminium cover	50.CR.010.1
4	1	Silenziatore / Muffler	URBAN
5	3	Vite M12x60 / Screw M12x60	50.73.280.1
6	3	Rondella M12 / Washer M12	50.73.705.1
7	1	Staffa Cruiser / Cruiser bracket	50.SS.642.0
8	5	Dado M8 flangiato / Flanged nut M8	50.73.393.1
9	1	Fascetta Ø 40/43 mm / Pipe clamp Ø 40/43 mm	50.FA.005.1
10	1	Tubo di raccordo / Link pipe	97CYA0006B
11	2	Dado rapido / Cage nut	50.66.009.1

**APPLICAZIONI / APPLICATIONS**

CODICE / CODE	SILENZIATORE / MUFFLER	
C.YA.0006.B	NON CATALIZZATO / NON CATALYZED	
C.YA.0006.K	CATALIZZATO / CATALYZED	