

MV Agusta Rivale 800 High License plate holder



Warning: Before proceeding with the assembling of the product, MV Agusta specifies that the user is liable for any incorrect installation of the product or its improper use. We recommend the installation of the kit to qualified personnel

The colors and finishing of the parts have to be considered as indicative.

PICTURES:

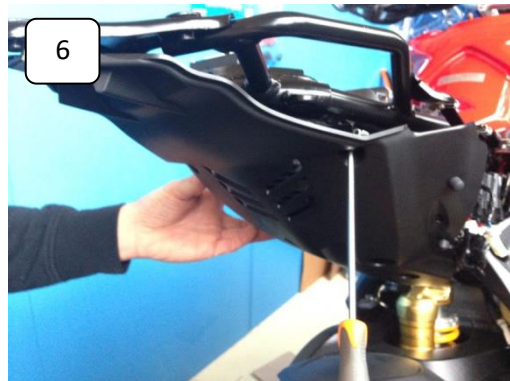
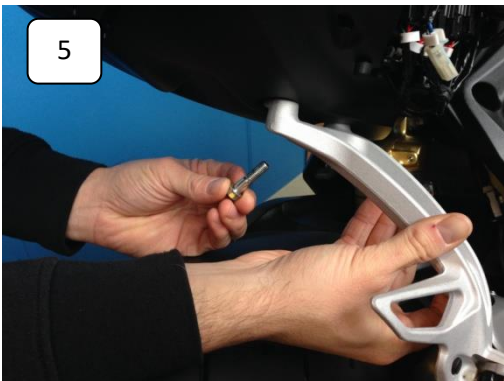
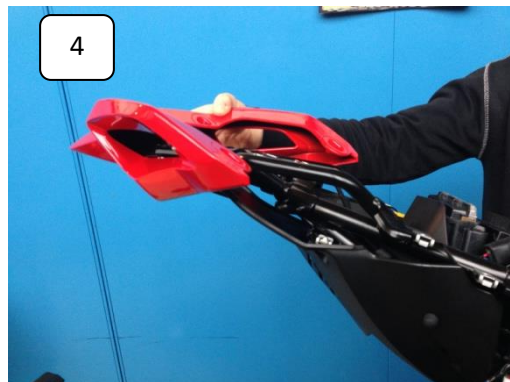

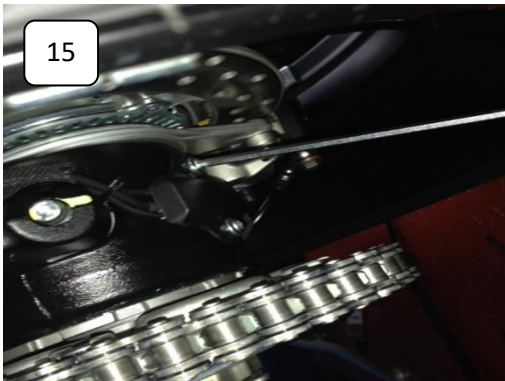
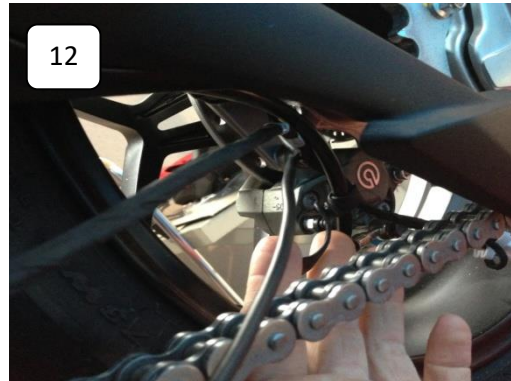
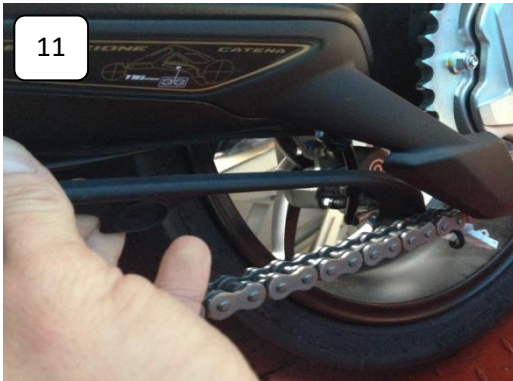
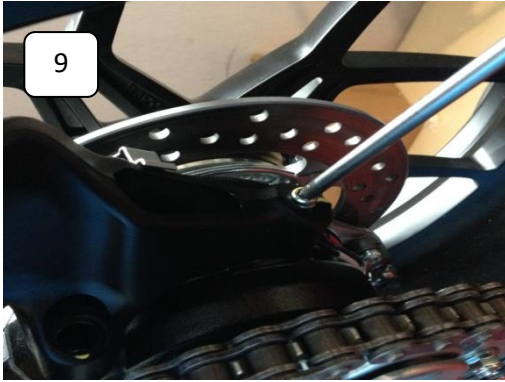

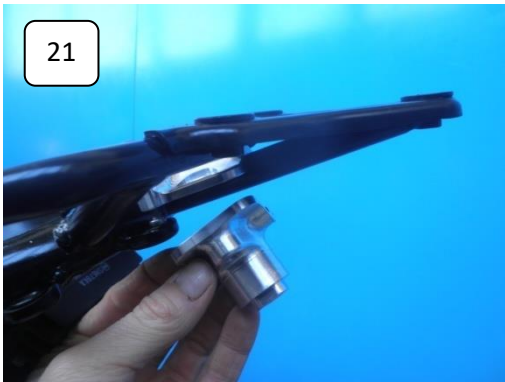
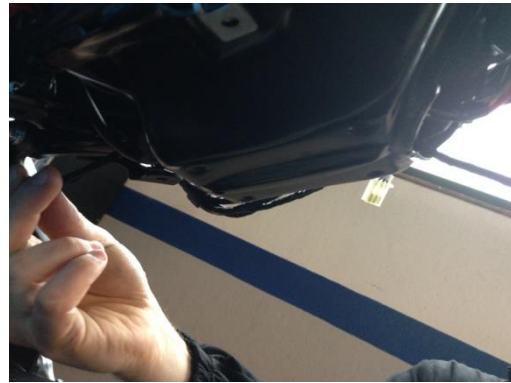
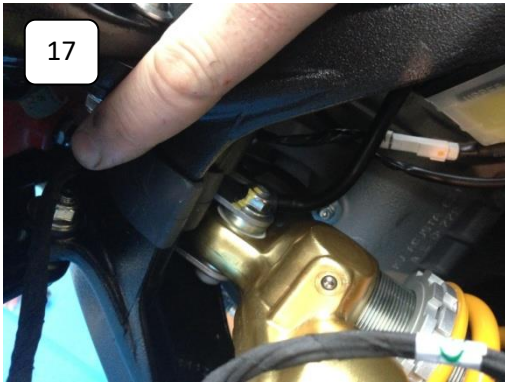



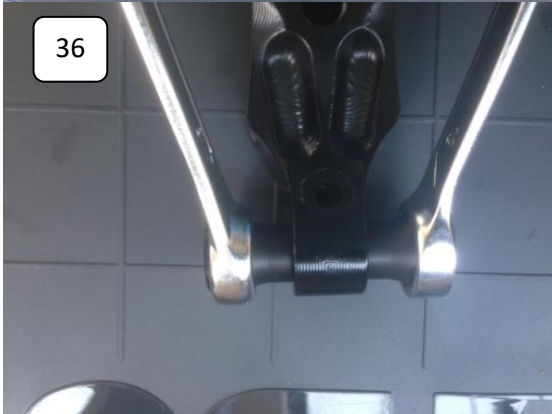

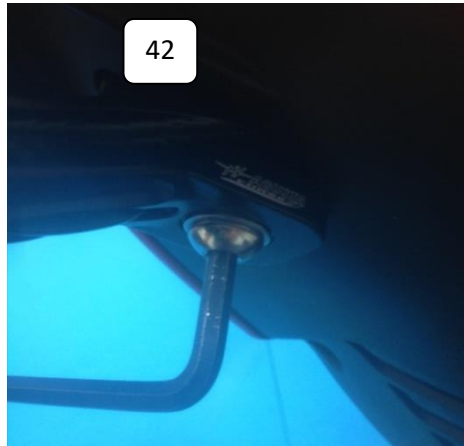
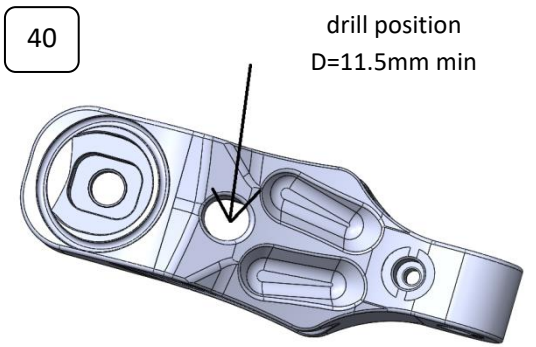
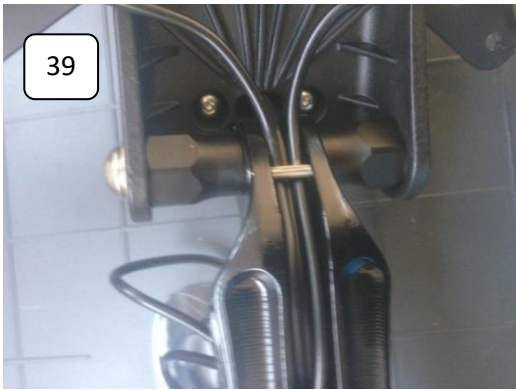
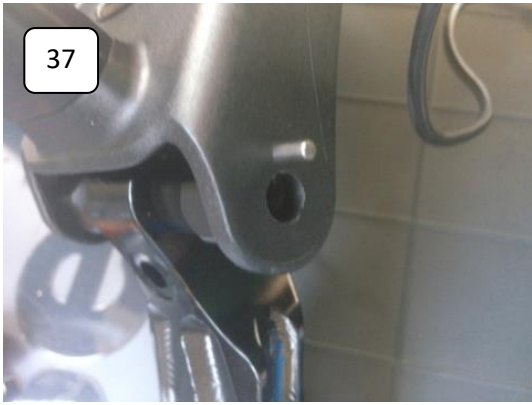

ENGLISH

DISASSEMBLING STEPS OF THE STANDARD LICENSE PALTE HOLDER (refers to numbered pictures):

1-2) Remove the bike's seat, lifting and removing lateral fairings. Disconnect the electric cable. see the picture.

3-4) Lift and remove the rear fairing.

5) Remove the passenger pegs.

6) Remove the mudguard

7-9) Remove the M12 screws (2pcs) and the M6 screw, which fix the original license plate holder to the swingarm. Disconnect the electric connectors of original tail tidy and remove it, see picture.

11-15) Following the pictures, remove the plastic cover and the plastic clamps of the electric wires. Take out only the electric cables and assemble again all the parts checking that cables and pipes are well fixed.

16) Put the new M12 screws (part 18-Annex 2) and tighten them. **RESPECT THE TIGHTENING TORQUE OF THE NEW SWINGARM SCREW** (available on the maintenance documents).

Insert the plastic caps (part 19-Annex 2).

17-19) Finally, put the cables in the under-seat unit and fix them properly with plastic straps. Check the positioning of the cables in order to avoid damage during the saddle's closure.

ASSEMBLING STEPS OF THE AFTERMARKET LICENSE PLATE HOLDER :

20) Put on the bracket the special aluminum clamp (upper part n°26 Annex 2)

21) Place on the rear frame the special aluminum clamp (lower part n°1 Annex 2) and fix the parts with the two screws (n°2 Annex 2);

22-23) Adjust the location of special aluminum clamps. These have to be centered with the bike's plane of symmetry.

ATTENTION: There is only one possible direction to fix these brackets. Check well the correct positioning of the aluminum bracket (part 15 Annex 2).

24-26) With two grab screw (n°20 Annex 2), set-up and minimize the backlash, see picture.

27) **ATTENTION:** during this step we suggest to use MV Agusta tool available in Mv Agusta spare parts kit cod. B8511_F .

The mudguard is the same as the original one but it has a specific hole where the new plate's support should be placed.

You can modify the original part but Mv Agusta decline any responsibility and /or damages to the bike or people.

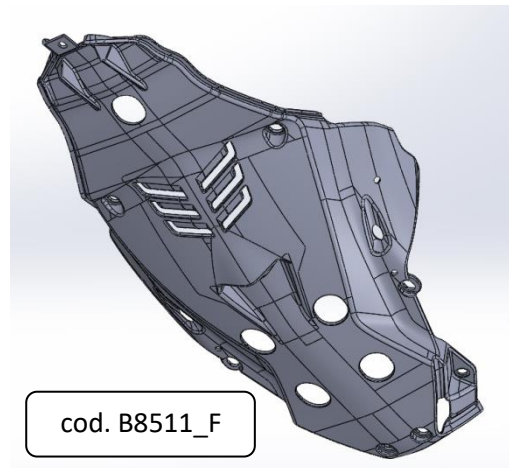

28-29) Fix the mudguard using the original screws

30) Fit the lateral fairing with rear clamps.

31) Assemble the license plate light on the plastic component as shown in the picture. Use screws M5x35mm.

32) Assemble the rear reflector on the dedicated support putting the washer and fastening the M5 hexagonal bolt. Assemble the rear-reflector support on the plate holder using the M5 bolts included in the kit.

33a-33b-33c) Assemble the indicators lights supports on the plate, using the M3 bolts (4pcs) see pictures. Fit carefully the indicators lights on the support paying attention to place the logo upwards, see picture. Fit both the indicators and set the direction of the light to about 30° respect to the license plate holder.

34) Place the M3 grub screws (n°16 Annex 2) on the bracket (n°15 Annex 2), see picture.

35) Assemble the special black hexagonal nut (n° 7 Annex 2, with hole) with M8 grub screw (pos. 8 Annex 2) and install these on the bracket as shown in the picture.

36) Use two tools, as shown in the picture, to block the aluminum hexagonal spacer (part n° 6 Annex 2, without hole),

37-38) Put 3mm dowel pin in the plastic plate's support (pos.17 Annex 2). It will block rotation to 30°.

39) Put the electric cables in dedicated compartment of the new license plate holder, see picture.

40) It is necessary to drill the plastic mudguard (cod. B8511_F) to allow the passage of electric cables. Use 11.5mm drill diameter minimal.

41-42) Fix the kit you just assembled on the special base through M10 screws (n°.13 Annex 2) , you already placed before. Put the O-ring as shown in the picture.

Link the electrical connections using the connectors integrated on the devices, insert the electrical resistors in the indicators lights wiring and check the correct flashing of the light

Place the electrical wiring in the under-seat unit and fix the cables with plastic straps in order to avoid damages due to vibrations. Check they don't obstruct the seat closure.

Set the positioning of the seat and check the correct closure.

43) Install the rear fairing with original screw.

ANNEX 1





