

ID.	DESCRIPCIÓN	DESCRIPTION	QTY.
1	Maleta	Case	1
2	Parrilla superior	Upper rack	1
3	Gomas	Rubbers	4
4	Respaldo	Backrest	1
5	Tornillo hexagonal M5x12 DIN 933	M5x12 DIN933 Hexagonal fastener	4
6	Arandelas M5 DIN 9021	M5 DIN 9021 washers	4
7	Tuerca M-6 din 6923	M6 DIN6923 nut	4
8	Pletinas	Plates	2
9	Tornillo hexagonal M6x20 DIN 933	M6x20 DIN933 Hexagonal fastener	4
10	Arandela M6 DIN 125-A	M6 DIN125-A washer	14
11	Tuerca M6 DIN 985	M6 DIN985 nut	10
12	Tornillo M6x15 DIN 7380 zincado	M6x15 DIN7380 fastener zinc coated	6
13	Tornillo M6x40 DIN 7380 zincado *	M6x40 DIN7380 fastener zinc coated *	4
14	Parrilla	Rack	1
15	Parrilla Ref. PP0001J (no incluida)	Rack part PP0001J (not included)	1
16	Plantilla taladros parrilla (2)	Drilling template rack (2)	1
17	Brida ondulada *	Wave bridle *	4

* Elementos necesarios si no se monta la parrilla de Customacces PP00015

Montaje con parrilla Customacces (15) utilizar accesorios suministrados ID.: (10) (11) (12).

Montaje con parrilla no Customacces utilizar accesorios suministrados ID.: (13) (17).

*Needed elements if the Customacces rack PP00015 is not mounted.

Mouting with Customacces rack (15) may use supplied accessories ID.: (10) (11) (12).

Mouting without Customacces rack may use supplied accessories ID.: (13) (17).

MALETA TRASERA RÍGIDA HARD BACK CASE

Ref.: MT0001N

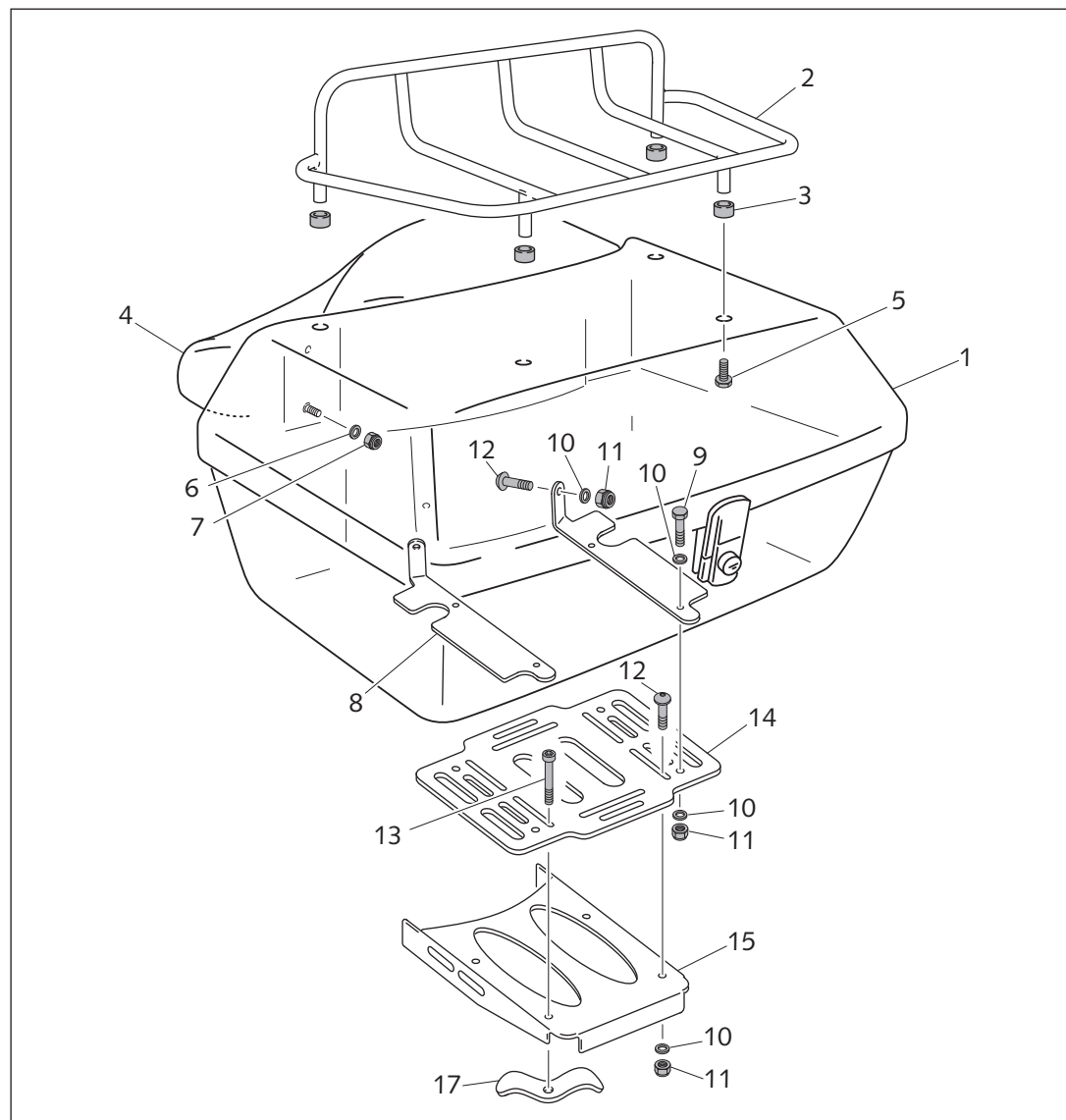



CUSTOMACCES

Pol. Ind. Can Castells - Av. Can Castells, 11-D
08420 Canovelles (Barcelona) SPAIN

INSTRUCCIONES DE MONTAJE - MOUNTING INSTRUCTIONS

MALETA TRASERA RÍGIDA HARD BACK CASE

Ref.: MT0001N

INSTRUCCIONES MONTAJE PARRILLA SUPERIOR POSICIÓN 2

- 1 - Abra la maleta (1) y coloque la plantilla suministrada (16) de manera que se adapte perfectamente a la parte interior de la tapa de la maleta tal i como muestra la figura adjunta.
- 2 - Marque los orificios de la plantilla en la maleta.
- 3- Taladre a diámetro 6mm dichas marcas.
- 4- Coloque la parrilla (2) y gomas (3) en la parte externa superior de la maleta.
- 5- Mediante los tornillos suministrados (5) fije todo el conjunto.

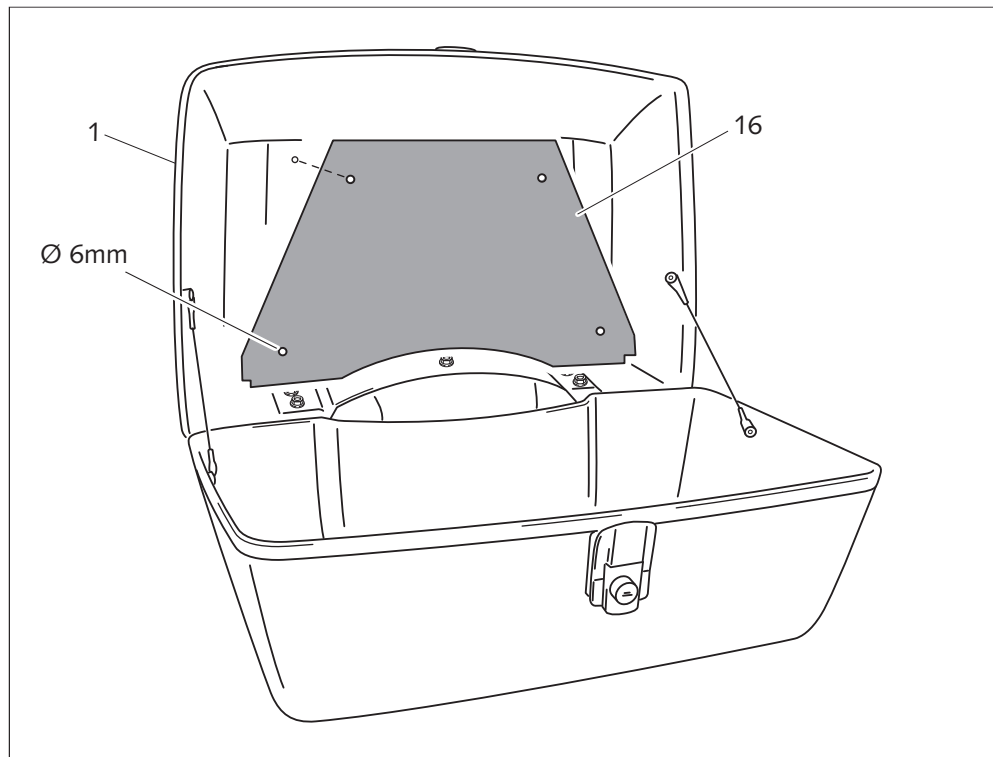

INSTRUCTIONS TO ASSEMBLE THE UPPER RACK POSITION 2

- 1 - Open the case (1) and place the template supplied (16) so it perfectly adapts in the lower part of the case cover interior, as the figure below shows.
- 2 - Mark the drills on the case.
- 3- Drill the marks with a 6mm diameter.
- 4- Place the rack (2) and rubbers (3) on the external upper part of the case.
- 5- Tight the set with the fasteners supplied (5).

