



By National Cycle

INSTALLATION AND OWNER'S MANUAL

P9BR308
for YAMAHA XVS1300 A

Please read and understand these instructions completely before installation to avoid any possible injury to yourself or damage to your motorcycle and / or accessory.

DEALER: These instructions contain important information for future reference and must be given to the customer.

PARTS LIST

Item	Part Number	Description	Qty.	Note
1	37-371178-000	Side Plate, Left	1	
2	37-371179-000	Side Plate, Right	1	
3	80-890002-000	Eye brow, Left	1	Assembled w/ cushion
4	80-890003-000	Eye brow, Right	1	Assembled w/ cushion
BAG 914				
5	34-340519-000	Spool, Rear	2	
6	34-340518-000	Spool, Front	2	
7	51-516455-000	Screw, M8 x 55	4	
8	34-342815-000	Spacer, Front	2	
9	44-441901-000	Cushion, Urethane	2	
10	34-342816-000	Spacer, Rear	2	
11	34-340506-010	Cover, Rear	2	

Report any missing parts directly to National Cycle, Inc. There is important code information located on the end panel of box that will be necessary when reporting missing parts.

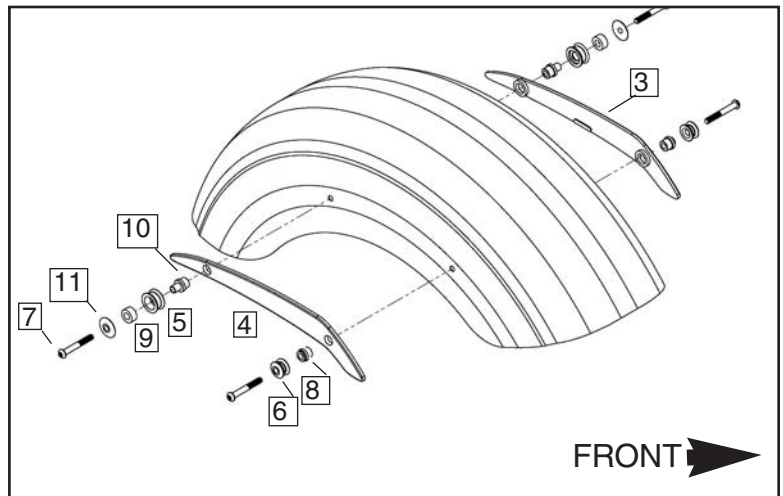
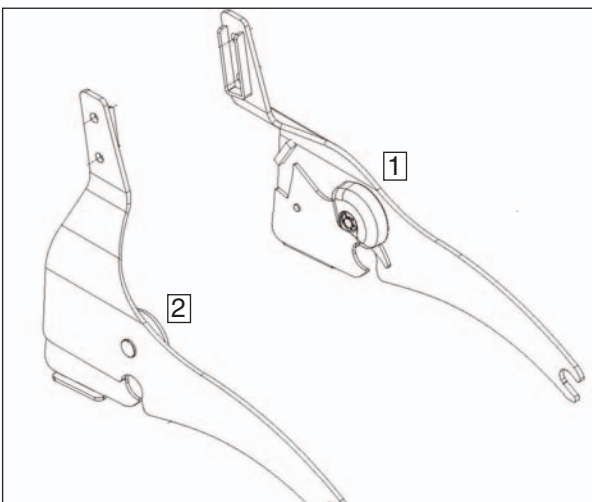

The following symbols are used in these instructions:



Special notes and cautionary measures.



Tips for facilitation of operation, control and adjustment, as well as maintenance work.

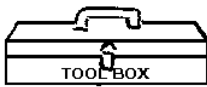

5mm Hex Wrench
Torque Wrench
Thread Lock, Medium Strength
such as Loctite® #243



Right and Left side of Motorcycle is determined while sitting on the bike.

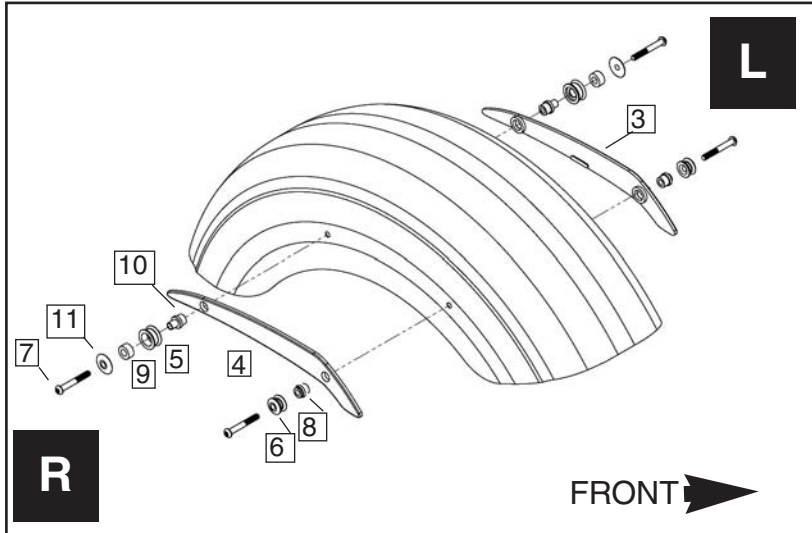

Figure 1

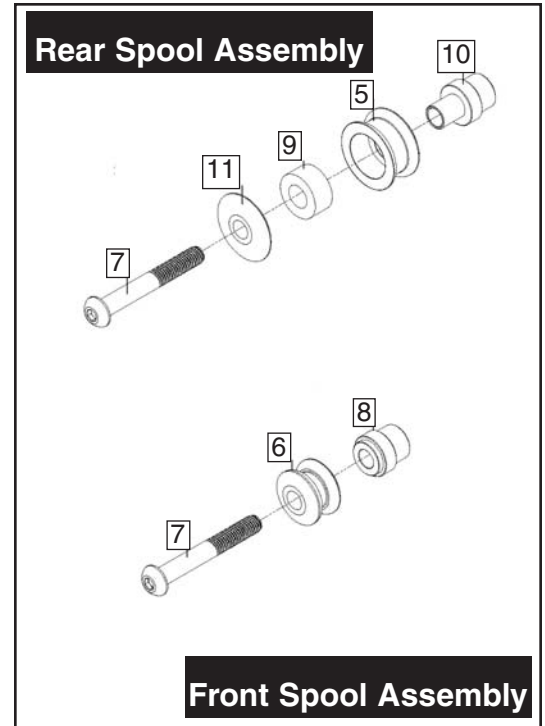

Figure 2

PREPARATION

1. Place motorcycle on flat and level ground with side stand securely in place.



Before installing fasteners we recommend you apply a small amount of Loctite® medium strength #243 thread retaining compound (or similar brand) to the threads of the button head screws (a) referenced on page 3 and to the M8 x 50 fasteners supplied in Bag 914. **(Thread Lock)**

INSTALLATION OF EYEBROW

1. Start on right side of the motorcycle and remove the 2 bolts from the fender and trim rail. Remove rear trim rail. Store bolts and trim rail, they will not be re-used. (5mm Hex Wrench)

SPOOL ASSEMBLY, FRONT AND REAR

2. Assemble front and rear spool assemblies into the right eyebrow (4) and fender. Do not fully tighten. This will allow some movement which aids in the side plate installation. **(5mm Hex Wrench) Figure 1.**



After final assembly fender mount screws will torque to: 22 Nm (17 ft/lb)

3. Repeat steps 1-2 for the left side fender assembly.

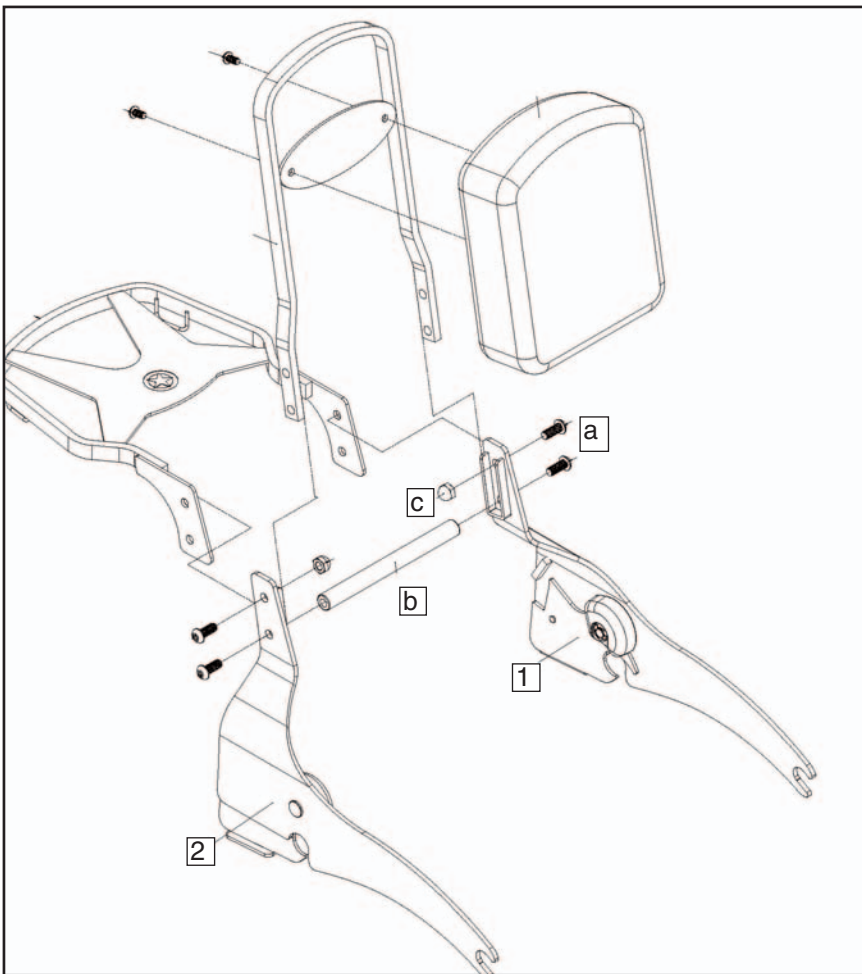



Figure 3

ASSEMBLY OF COMPONENTS

 The Paladin Backrest and Luggage Rack are sold separately. Backrest part no. P9800A; rack part no. P9900.

 Before installing fasteners we recommend you apply a small amount of Loctite® medium strength #243 thread retaining compound (or similar brand) to the threads of the button head screws (a) and to the M8 x 50 screws used to attach eyebrow. (Page 2, step 2.) **(Thread Lock)**

1. Assemble side plates (1) and (2) to the Paladin backrest alone or with the Paladin luggage rack. **(5mm Hex Wrench) Figure 3**

2. Use the button head screws (a) and the support stay (b) provided with the backrest to complete assembly of the side plates. **(5mm Wrench) Figure 3.**

3. Torque screws (a) and cap nuts (c) to 22 Nm (17 ft/lb). **(Torque Wrench)**

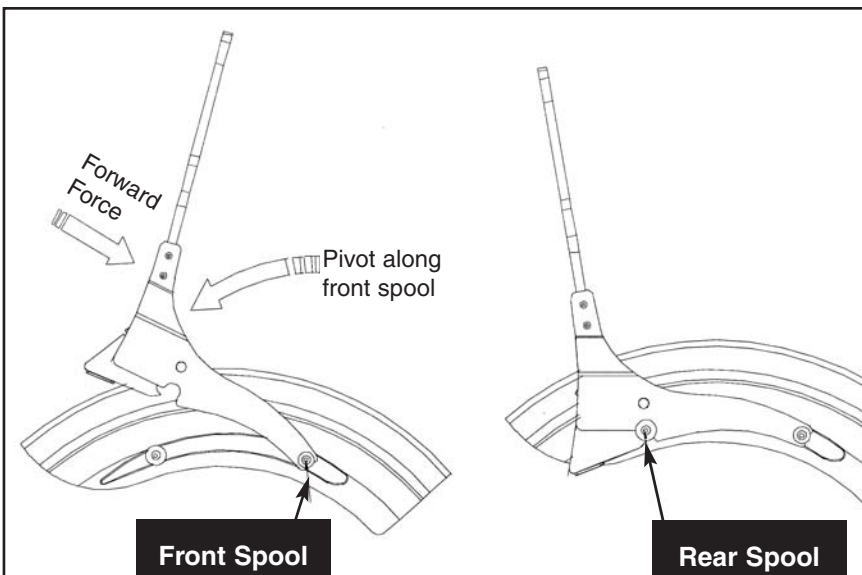

Figure 4

INSTALL ASSEMBLY TO MOTORCYCLE

7. Check that QuickSet 3 is unlocked. Install backrest assembly onto motorcycle by first positioning side plates on front spools. With smooth continuous forward force, rotate the backrest assembly downward on to the rear spools while pushing down firmly to engage side plate latch mechanism with the rear spools. **Figure 4.**

8. Tighten the four M8 x 50 screws to 22 Nm (17 ft/lb) **(Torque Wrench)**

9. Make sure to lock the backrest in place before operating the motorcycle.

10. To remove backrest assembly, stand behind vehicle. Unlock and pull up gently on side plate latch mechanisms. Rotate backrest assembly upward and then pull back to disengage front spools.

PATENT No. 6484914

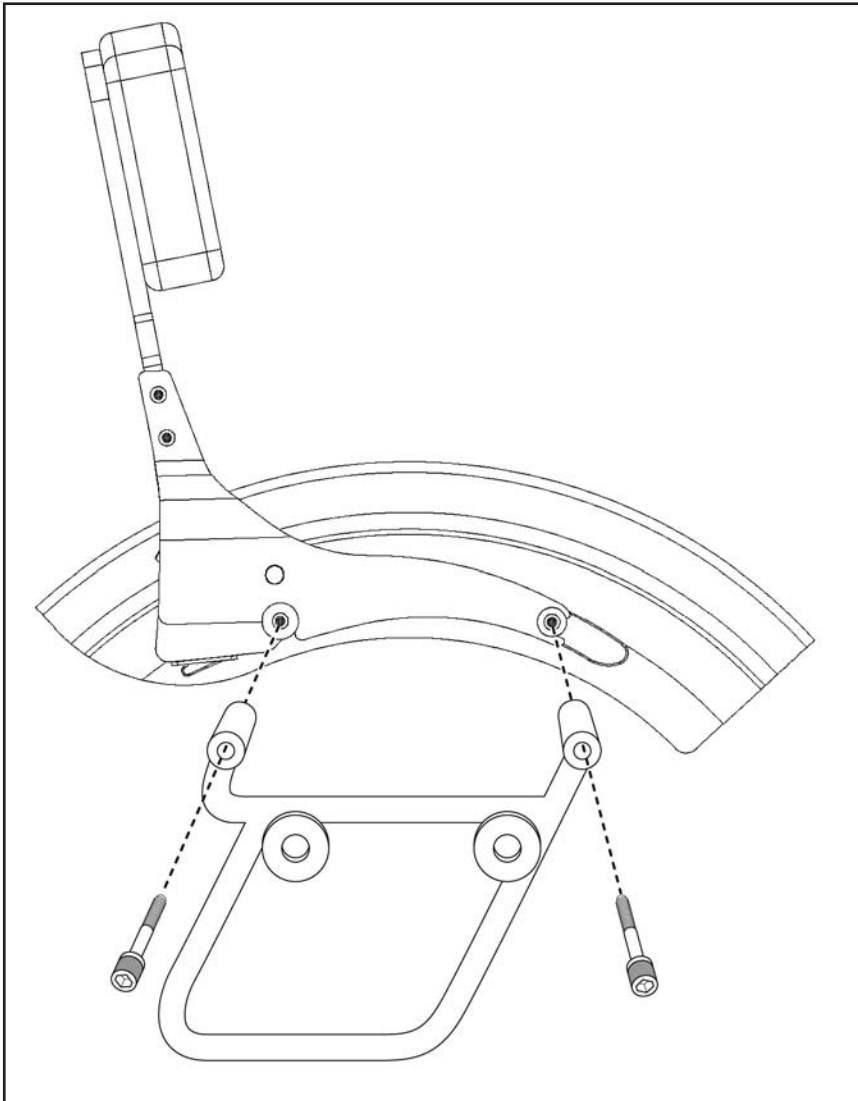



Figure 5

INSTALLING PALADIN KIT WITH CRUISE-LINER SADDLEBAGS

 For this installation you will need the screws from the Cruisliner Saddlebag Kit

 Before installing fasteners we recommend you apply a small amount of Loctite® medium strength #243 thread retaining compound (or similar brand) to the threads of the M8 screws used to attach frame to eyebrow. **(Thread Lock)**

1. Refer to page one of this instruction manual and install the eyebrow and spool assembly as instructed.

Rear Screws

2. Remove the *rear* screws from one side.

3. Install the frame bracket using the M8-1.25 x 75 screw from Bag 874 of the Cruisliner saddlebag kit at rear. **(5mm Hex Key) Figure 5**

4. Install the front mount point of saddlebag frame with the M8-1.25 x 75 screw. **(5mm Hex Key) Figure 5**

5. Repeat installation on other side.

6. Tighten screws to: M8 = 22 Nm (17 ft/lb)

WARNING

Maximum load for the Luggage Rack is 5 Kg (11 lbs).

When mounting the Backrest assembly, listen for the audible "click" indicating that the latches are in place. Always lock the QuickSet 3® Side Mount Plate before using your motorcycle. This insures the utmost in safety.

Never ride your motorcycle with loose accessory mounting hardware. Check the hardware for tightness regularly.

Today's motorcycles are built with enough frame rigidity to withstand the moderate loads imposed on them by the foreseeable addition of an accessory. If the accessory(ies) adversely affects your motorcycle's stability, immediately remove the accessory(ies). Do not ride a motorcycle that exhibits unsafe handling traits.

Have experienced service personnel correct any problem before riding with the accessory(ies) installed. For further questions concerning handling problems associated with an accessory(ies), contact your dealer, motorcycle manufacturer, or accessory manufacturer.

MAINTENANCE

The high quality chrome finish of your National Cycle Paladin rack assembly can be maintained with any quality chrome cleaner and or polish. Overtime spools can be lubricated with any common household lubricant.