

THIS SHEET INCLUDES FITTING INSTRUCTIONS FOR THE FOLLOWING PARTS:

Secondary Alternator Cover Part No. EC-790-2018-1-GBR / Secondary Clutch Cover Part No. EC-790-2018-2-GBR /  
Secondary Clutch Cover Part No. EC-790-2018-5-GBR / Paddock Stand Bobbin Set Part No. BA12-10-1-5-GBR-SET /  
Brake Lever Guard Part No. BLG-14-A160-GBR / Clutch Lever Guard Part No. CLG-14-A160-GBR



**SECONDARY ALTERNATOR COVER PART NO. EC-790-2018-1-GBR**

- 1 Remove 4 existing bolts from the stock Alternator cover, shown as position Bolt 1, 2, 3 & 4.
- 2 Place the Secondary Alternator Cover over the stock cover.
- 3 Assemble 4 replacement bolts loosely in the correct position as shown.
- 4 Tighten bolts to a Torque of 10Nm as per Manufacturer's recommendations.  
DO NOT OVERTIGHTEN.

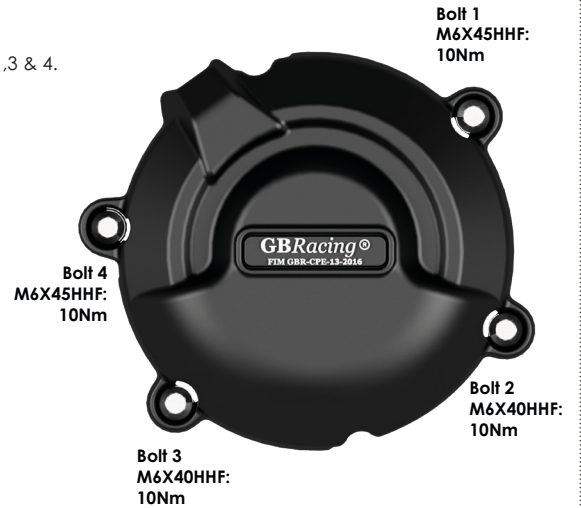
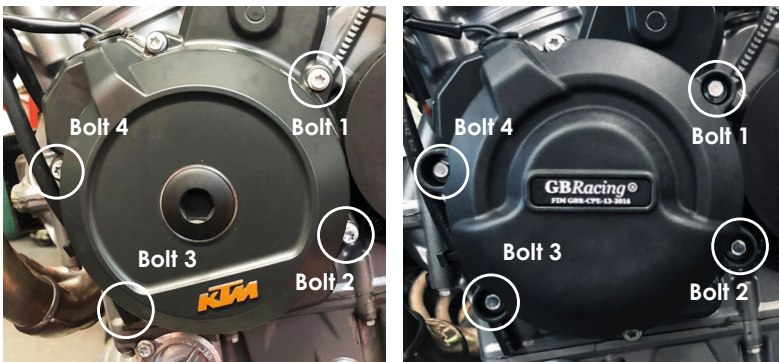

**SECONDARY CLUTCH COVER PART NO. EC-790-2018-2-GBR**

- 1 Remove 4 existing bolts from the stock Clutch cover, shown as position Bolt 1, 2, 3 & 4.
- 2 Place the Secondary Clutch Cover over the stock cover.
- 3 Assemble 4 replacement bolts loosely in the correct position as shown.
- 4 Tighten bolts to a Torque of 10Nm as per Manufacturer's recommendations.  
DO NOT OVERTIGHTEN.

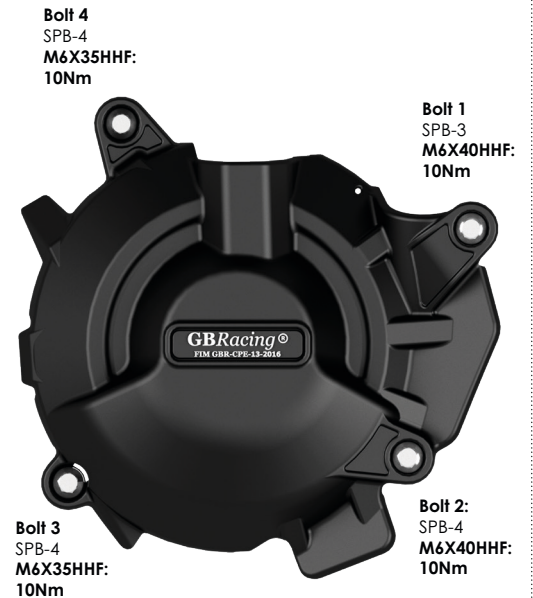
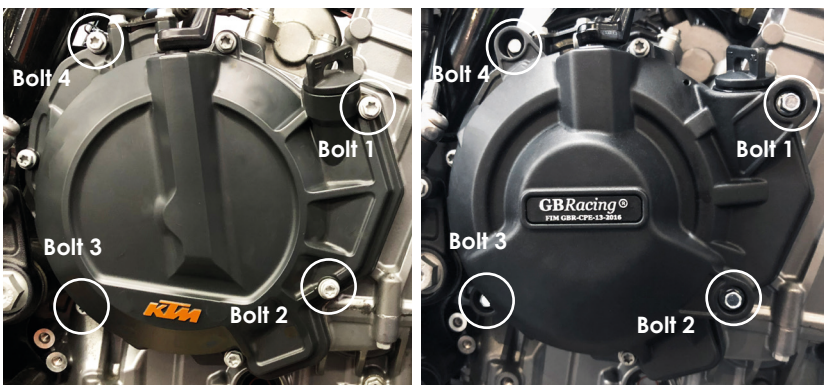

**SECONDARY WATER PUMP COVER PART NO. EC-790-2018-5-GBR**

- 1 Fitting requires a COLD engine.
- 2 Decompress the system before loosening existing stock bolts by removing the radiator cap. **ONLY WHEN ENGINE IS COLD.**
- 3 Have all 3 replacement bolts to hand before removing existing stock bolts.
- 4 Remove 3 existing bolts from the stock water pump cover, shown as position bolts 1, 2 & 3.  
Note: When the water pump bolts are removed there will be slight fluid loss.
- 5 Place the secondary water pump over the stock cover.
- 6 Assemble 3 replacement bolts, loosely in the correct position as shown.
- 7 Tighten bolts to a Torque of 10Nm. **DO NOT OVERTIGHTEN.**
- 8 Check coolant level & top up if necessary before starting engine.

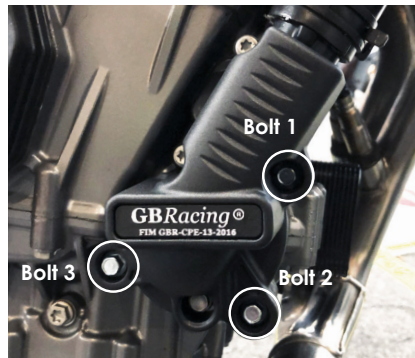
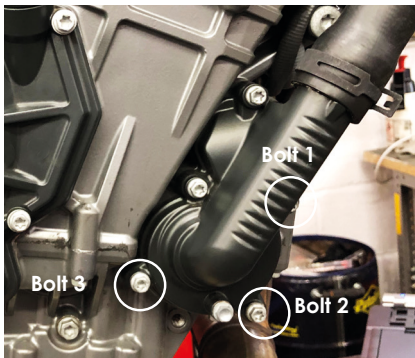

**PADDOCK STAND / BOBBIN SET PART NO. BA12-10-1-5-GBR-SET**

- 1 Assemble the M10 Stainless Steel bolt through the moulded bobbin and the Black Anodised Bush.
- 2 Tighten bolts to the swing arm boss, 8 N/m. **DO NOT OVERTIGHTEN.**

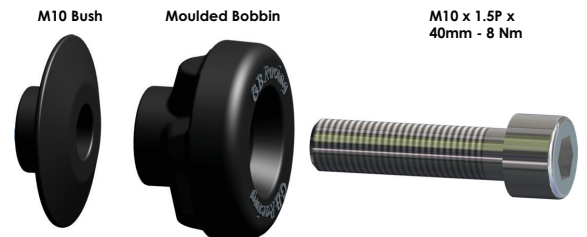
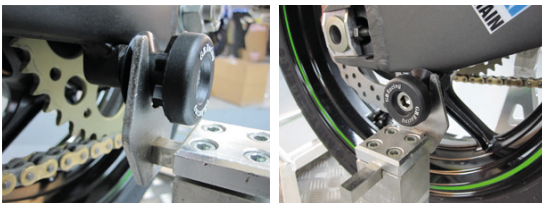

**UNIVERSAL BRAKE LEVER GUARD WITH 14mm INSERT (Fits tube inside diameters from 13.6mm to 15.7mm)**

**PART NO. BLG-14-A160-GBR**

- 1 Remove existing bar end and replacing it with supplied bar end.
- 2 Tighten bolt until the lever protector is tight and does not move up or down under normal pressure.
- 3 Do not ride if you are unsure if it is tight enough and always get a trained technician to confirm.

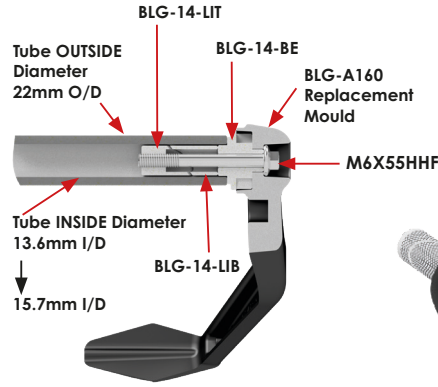

**UNIVERSAL CLUTCH LEVER GUARD WITH 14mm INSERT (Fits tube inside diameters from 13.6mm to 15.7mm)**

**PART NO. CLG-14-A160-GBR**

- 1 Remove existing bar end and replacing it with supplied bar end.
- 2 Tighten bolt until the lever protector is tight and does not move up or down under normal pressure.
- 3 Do not ride if you are unsure if it is tight enough and always get a trained technician to confirm.

