



C-Bow

KAWASAKI ER6-n/f  
Baujahr ab 2012

Art.-Nr.: 630.2516 schwarz

KAWASAKI ER6-n/f  
Baujahr ab 2012

Art.-Nr.: 4002.044.131 schwarz

## Montage

Der Bausatz umfasst die folgenden Teile:

Stück	Bestellnr.	Bezeichnung
2	700007063	C-Bow schwarz
1	700007914	C-Bow Halteadapter hinten
1	700007915	C-Bow Halteadapter vorne links
1	700007916	C-Bow Halteadapter vorne rechts
1	700007917	Querstrebe
2	150.923	Inbusschrauben M6x30
12	150.916	Sechskantschraube M6 x 18mm
12	150.809	U-Scheibe Ø6,4
2	150.810	Karosseriescheibe Ø6,4xØ18x1,5mm
2	150.799	selbstsichernde Mutter M6

Nur bei gleichzeitigem Anbau mit Alu Rack:

8	150.813	Aludistanzen Ø15xØ9x15mm
8	150.831	Sechskantschraube M6 x 30mm

Die hinteren Blinker verbleiben in Originalposition.

**Tip:**

Ziehen sie alle zugänglichen Schrauben zuerst nur locker an. Nachdem alles montiert ist, werden die Schrauben dann auf das entsprechende Anzugsmoment festgezogen. Dadurch wird sichergestellt, dass das Produkt spannungsfrei angebaut ist. Schrauben zusätzlich mit Sicherungsmittel sichern. Anzugsmomente des Motorradherstellers beachten!



Anzugsmomente des Motorradherstellers beachten!  
Nach der Montage alle Verschraubungen auf festen Sitz kontrollieren!  
Bitte beachten Sie unsere beigefügten Serviceinformationen.



Hepco & Becker GmbH  
An der Steinmauer 6  
D-66955 Pirmasens  
Tel.: 06331 - 1453 - 100  
Fax: 06331 - 1453 - 120  
eMail: [vertrieb@hepco-becker.de](mailto:vertrieb@hepco-becker.de)  
[www.hepco-becker.de](http://www.hepco-becker.de)



Krauser GmbH  
An der Steinmauer 6  
D-66955 Pirmasens  
Tel.: 06331 - 1453 - 250  
Fax: 06331 - 1453 - 260  
eMail: [vertrieb@krauser.de](mailto:vertrieb@krauser.de)  
[www.krauser.de](http://www.krauser.de)



C-Bow

KAWASAKI ER6-n/f  
Baujahr ab 2012

Art.-Nr.: 630.2516 schwarz

KAWASAKI ER6-n/f  
Baujahr ab 2012

Art.-Nr.: 4002.044.131 schwarz

## Montage

Sitzbank abnehmen.  
Zur besseren Montage die Halteadapter  
zuerst locker mit dem Wing verschrauben.  
Hierzu die Sechskantschrauben M6x18  
sowie U-Scheiben Ø6,4 verwenden.



**1**

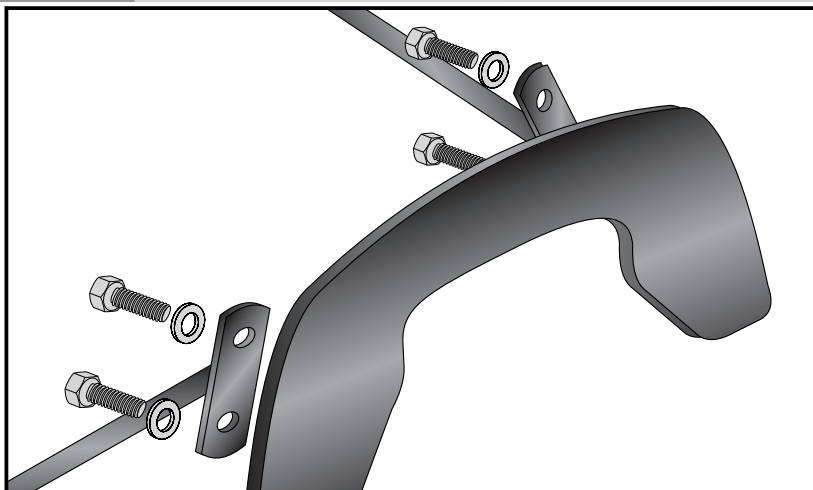

Befestigung vorne links und rechts:  
An der vorderen Verschraubung der  
Seitenverkleidung.  
(Original Schraube entfällt)  
Den Adapter mit der Sechskantschraube  
M6x18 sowie Karosseriescheibe  
Ø18xØ6,4x1,5mm montieren.



**2**

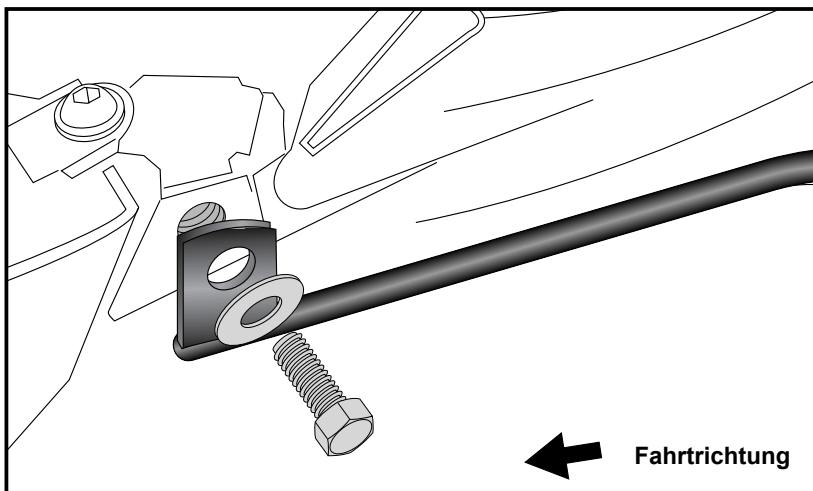

Befestigung hinten links und rechts:  
Die beiden Originalschrauben des  
Heckkotflügels ausdrehen (entfallen)  
Den hinteren Halteadapter an den nun  
freien Bohrungen mit den Inbusschrauben  
M6x30 montieren.

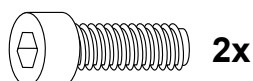

**3**

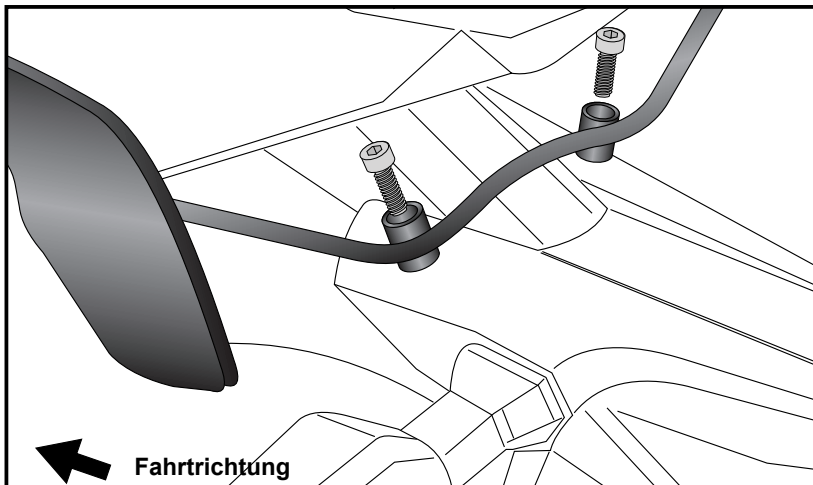



C-Bow

KAWASAKI ER6-n/f  
Baujahr ab 2012

Art.-Nr.: 630.2516 schwarz

KAWASAKI ER6-n/f  
Baujahr ab 2012

Art.-Nr.: 4002.044.131 schwarz

## Montage

### Befestigung der Querstrebe:

Diese verläuft unter dem Innenkotflügel quer zur Fahrtrichtung. Sie wird mit den Sechskantschrauben M6x18 sowie U-Scheiben Ø6,4 und selbstsichernden Muttern M6 montiert. Die Strebe so ausrichten daß sich die Rundung in den Innenkotflügel anlegt.

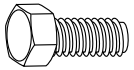

2x



2x



4x

4

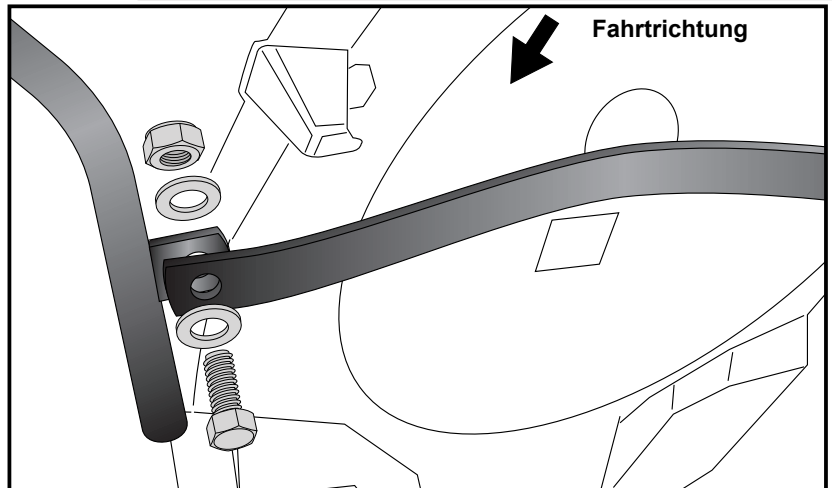

### Anbau zusammen mit einem Alurack:

Bei gleichzeitigem Anbau von Alurack und C-Bow müssen zwischen Wing und Halteadapter die Aludistanzen Ø15xØ9x15mm montiert werden. Zur Verschraubung die Sechskantschrauben M6x30 verwenden.





C-Bow

**KAWASAKI ER6-n/f**  
from date of manufacture 2012

Item.-No.: 630.2516 black

**KAWASAKI ER6-n/f**  
from date of manufacture 2012

Item.-No.: 4002.044.131 black

## Assembling instructions

The kit includes the following parts:

Quant	item no.	description
2	700007063	C-Bow black
1	700007914	C-Bow adapter rear
1	700007915	C-Bow adapter front left
1	700007916	C-Bow adapter front right
1	700007917	Bracing bow
2	150.923	allen screw M6x30
12	150.916	hexagon bolt M6 x 18mm
12	150.809	washer Ø6,4
2	150.810	body washer Ø6,4xØ18x1,5mm
2	150.799	self lock nut M6

Mounting together with an alurack:

8	150.813	alu spacer Ø15xØ9x15mm
8	150.831	hexagon bolt M6 x 30mm

The rear blinkers remain in their original position.

Tip:

Fit all parts and screw on not too strong. After mounting all parts, the screws should be tightened to the torque specified. This guarantees, that the kit is mounted without tension.



Control all screw connections after the assembling for tightness!  
Please notice our enclosed service information.



**Hepco & Becker GmbH**  
An der Steinmauer 6  
D-66955 Pirmasens  
Tel.: +49 6331 - 1453 - 100  
Fax: +49 6331 - 1453 - 120  
eMail: [vertrieb@hepco-becker.de](mailto:vertrieb@hepco-becker.de)  
[www.hepco-becker.de](http://www.hepco-becker.de)



**Krauser GmbH**  
An der Steinmauer 6  
D-66955 Pirmasens  
Tel.: +49 6331 - 1453 - 250  
Fax: +49 6331 - 1453 - 260  
eMail: [vertrieb@krauser.de](mailto:vertrieb@krauser.de)  
[www.krauser.de](http://www.krauser.de)



## C-Bow

**KAWASAKI ER6-n/f**  
from date of manufacture 2012

Item.-No.: 630.2516 black

**KAWASAKI ER6-n/f**  
from date of manufacture 2012

Item.-No.: 4002.044.131 black

### Assembling instructions

Dismantle seat.  
For easy assembling fix the C-Bow to the adapters first.  
Use hexagon bolts M6 x 18 and washers  $\varnothing 6,4$ .



**1**

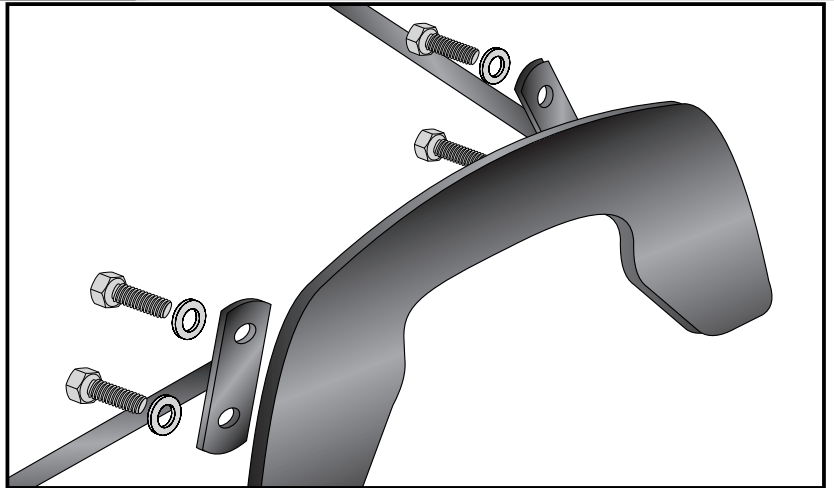

Fastening front left + right:  
dismantle original screws at the front bolting of the fairing (screws are obsolete).  
Fix the adapter with hexagon screws M6 x 18mm and washers  $\varnothing 18 \times \varnothing 6,4 \times 1,5 \text{mm}$



**2**

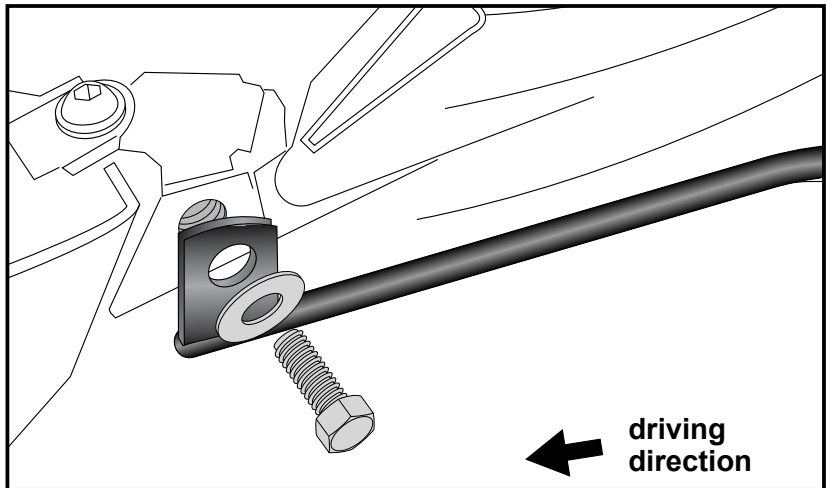

Fastening rear left + right:  
dismantle original screws of the rear fender (screws are obsolete).  
Fix the adapter with allen screws M6 x 30mm.

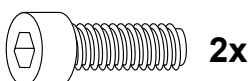

**3**

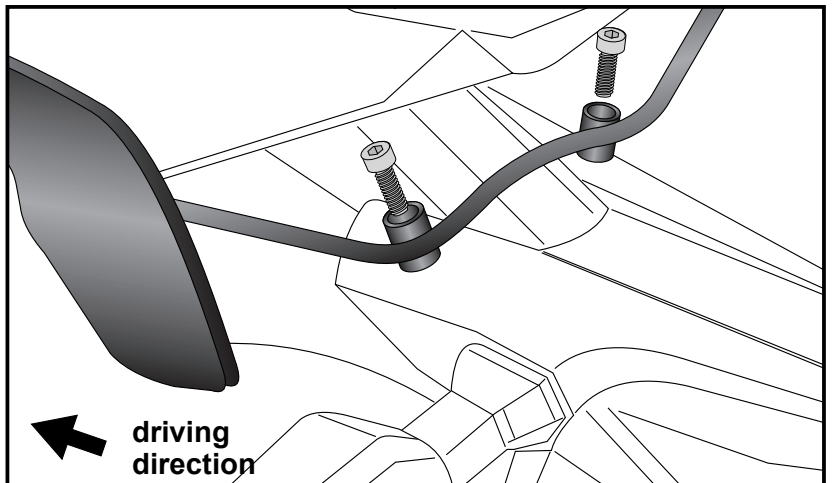



**C-Bow**

**KAWASAKI ER6-n/f**  
 from date of manufacture 2012

Item.-No.: 630.2516 black

**KAWASAKI ER6-n/f**  
 from date of manufacture 2012

Item.-No.: 4002.044.131 black

**Assembling instructions**

Fastening of the bracing bow:  
 under the rear fender.  
 Use hexagon bolts M6 x 18,  
 washers  $\varnothing 6,4$  and self lock nuts M6. Align  
 the bracing bow so that the curve applies  
 to the inner fender.

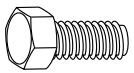

**2x**



**2x**



**4x**

**4**

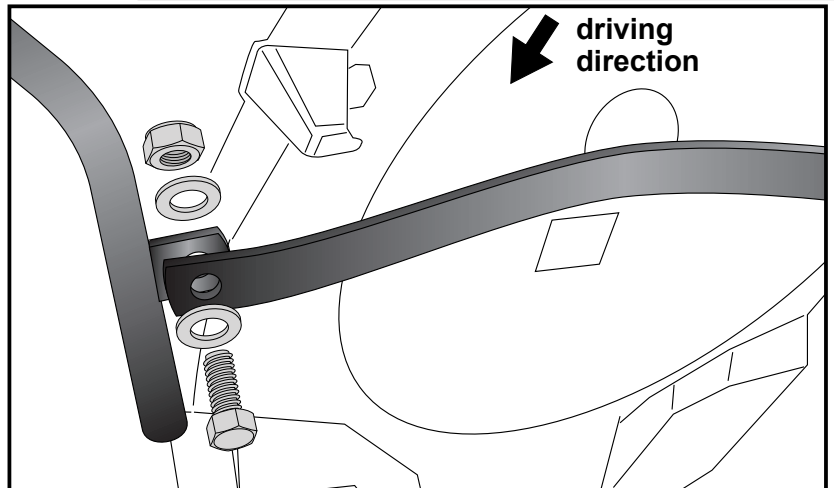

Mounting together with a Alurack:  
 alu spacers  $\varnothing 15 \times \varnothing 9 \times 15 \text{mm}$  must be  
 sandwiched between C-Bow and adapter  
 $\varnothing 15 \times \varnothing 9 \times 15 \text{mm}$ .  
 Use hexagon bolts M6 x 30 for fixing.

