

C-Bow



KTM 125 Duke

KTM 125 Duke

Art.-Nr.: 630.7504 schwarz

Art.-Nr.: 4011.006.131 schwarz

Montage

Der Bausatz umfaßt die folgenden Teile:

Stück	Bestellnr.	Bezeichnung			
2	700007063	C-Bow schwarz	10	150.809	U-Scheibe Ø6,4
1	700007787	C-Bow Halteadapter links vorne	4	150.810	U-Scheibe Ø8,4
1	700007788	C-Bow Halteadapter links hinten	2	151.172	Stahldistanzen Ø10xØ7x7mm
1	700007789	C-Bow Halteadapter rechts vorne	2	150.826	Aludistanzen Ø18xØ7x20mm
1	700007790	C-Bow Halteadapter rechts hinten	2	150.800	selbstsichernde Muttern M8
1	700007791	Halteflasche	2	270.113	Kunststoffkappen M8
2	150.768	Inbusschraube M6x45			
2	150.786	Inbusschrauben M8x40			
2	150.785	Inbusschrauben M8x35			
8	150.916	Sechskantschraube M6 x 18mm			

Die hinteren Blinker verbleiben
in der Originalposition.



Anzugsmomente des Motorradherstellers beachten!
Nach der Montage alle Verschraubungen auf festen Sitz kontrollieren!
Bitte beachten Sie unsere beigefügten Serviceinformationen.



Hepco & Becker GmbH
An der Steinmauer 6
D-66955 Pirmasens
Tel.: 06331 - 1453 - 100
Fax: 06331 - 1453 - 120
eMail: vertrieb@hepco-becker.de
www.hepco-becker.de



Krauser GmbH
An der Steinmauer 6
D-66955 Pirmasens
Tel.: 06331 - 1453 - 250
Fax: 06331 - 1453 - 260
eMail: vertrieb@krauser.de
www.krauser.de

C-Bow

KTM 125 Duke

Art.-Nr.: 630.7504 schwarz



KTM 125 Duke

Art.-Nr.: 4011.006.131 schwarz

Montage

Montage der Haltelasche hinten unten:

Die beiden Schrauben unter dem Kotflügel in Höhe der Blinker ausdrehen.

Die Haltelasche an den nun freien Bohrungen mit den Inbusschrauben M6x45 sowie U-Scheiben Ø6,4 befestigen.

Zwischen Lasche und Rahmen zuerst die Stahldistanz Ø10xØ7x7mm und dann die Aludistanz Ø18xØ7x20mm fügen.

Schrauben noch nicht ganz festziehen.

1

Fahrtrichtung →

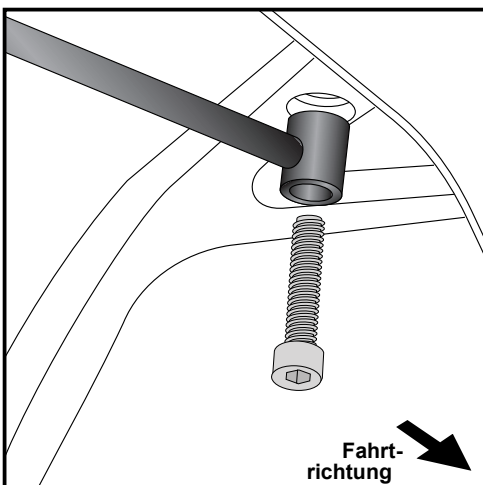
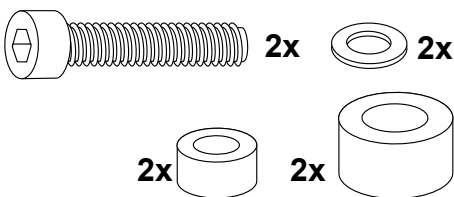
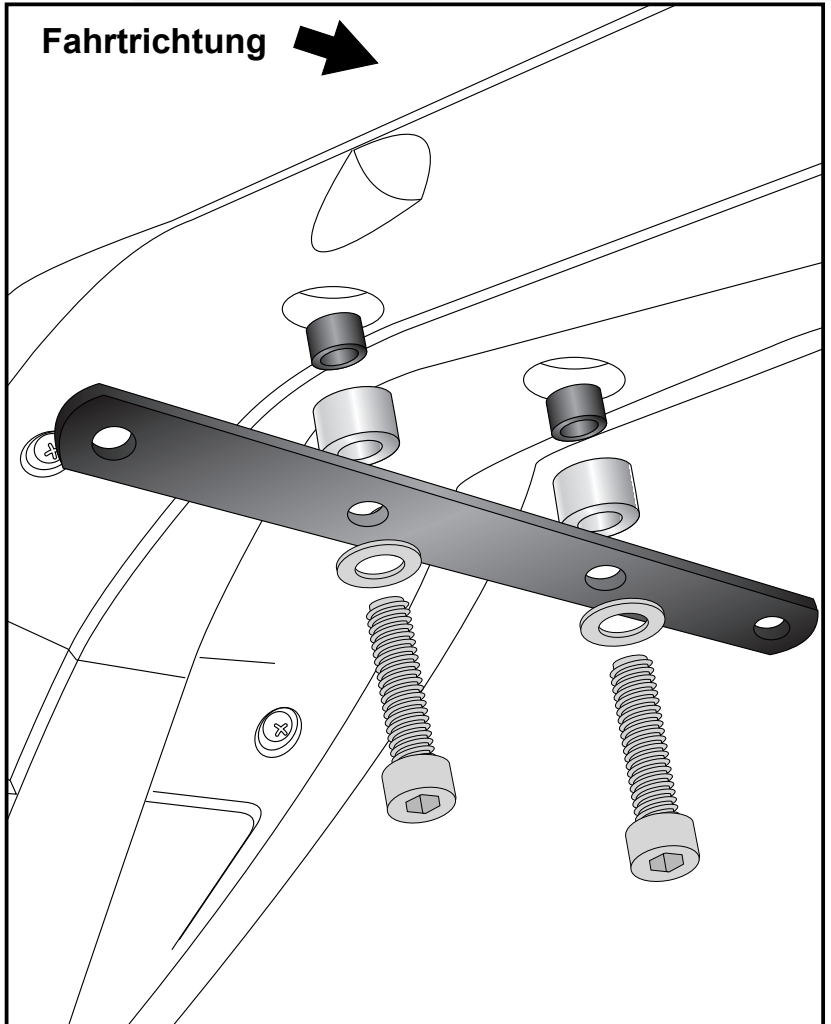

2

Montage der Halteadapter vorne links und rechts:

Die hintere Schraube des Soziusfußrastenauslegers ausdrehen (entfällt). An der nun freien Bohrung den Halteadapter mit der Inbusschraube M8x40 sowie U-Scheibe Ø8,4 befestigen. Noch nicht festziehen.



C-Bow

KTM 125 Duke

Art.-Nr.: 630.7504 schwarz



KTM 125 Duke

Art.-Nr.: 4011.006.131 schwarz

Montage

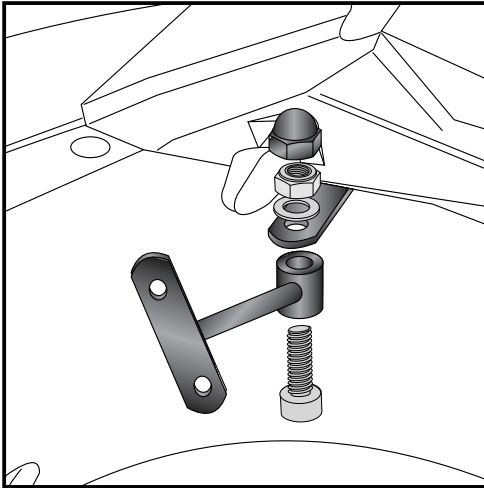

3

Montage der Halteadapter hinten links und rechts:

Die Befestigung erfolgt an der zuvor montierten Haltetasche die unterhalb des Kotflügels verläuft.
Den Halteadapter von unten mit der Inbusschraube M8x35 befestigen. Von oben mit der U-Scheibe Ø8,4 und der selbstsichernder Mutter M8 verschrauben.
Kunststoffkappen zur Abdeckung der Mutter verwenden.
Noch nicht festziehen.



Montage des C-Bow:

C-Bow Halter mit den Halteadaptern verschrauben. Zur Befestigung die Sechskantschrauben M6 x 18 mit U-Scheiben ø6,4 verwenden.

Teile ausrichten und sämtliche Schraubverbindungen festziehen.



4

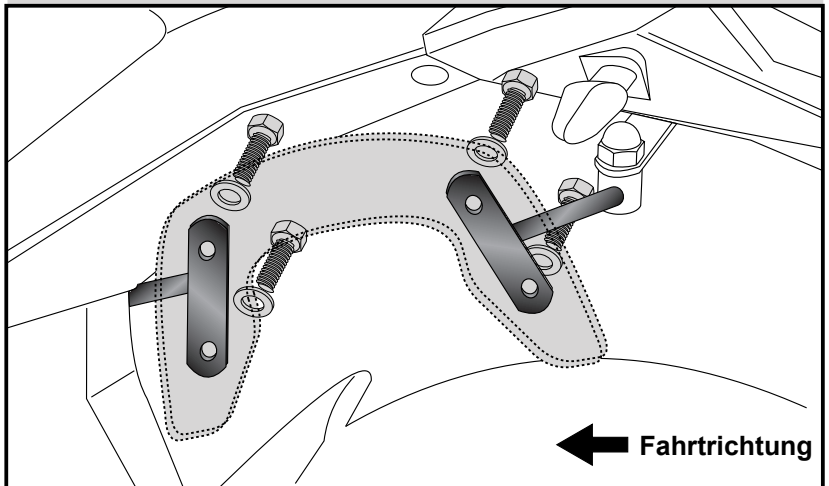

C-Bow

KTM 125 Duke

Item - No.: 630.7504 black



KTM 125 Duke

Item - No.: 4011.006.131 black

Assembling instructions

The kit includes the following parts:

Quant	item no.	description
2	700007063	C-Bow schwarz
1	700007787	C-Bow adapter left front
1	700007788	C-Bow adapter left rear
1	700007789	C-Bow adapter right front
1	700007790	C-Bow adapter right rear
1	700007791	Holding adapter
2	150.768	allen screw M6x45
2	150.786	allen screw M8x40
2	150.785	allen screw M8x35
8	150.916	hexagon bolt M6 x 18mm
10	150.809	washer Ø6,4
4	150.810	washer Ø8,4
2	151.172	steel spacer Ø10xØ7x7mm
2	150.826	alu spacer Ø18xØ7x20mm
2	150.800	self lock nuts M8
2	270.113	plastic cap M8

The rear blinkers remain in their original position.



Control all screw connections after the assembling for tightness!
Please notice our enclosed service information.



Hepco & Becker GmbH
An der Steinmauer 6
D-66955 Pirmasens
Tel.: +49 6331 - 1453 - 100
Fax: +49 6331 - 1453 - 120
eMail: vertrieb@hepco-becker.de
www.hepco-becker.de



Krauser GmbH
An der Steinmauer 6
D-66955 Pirmasens
Tel.: +49 6331 - 1453 - 250
Fax: +49 6331 - 1453 - 260
eMail: vertrieb@krauser.de
www.krauser.de

C-Bow

KTM 125 Duke

Item - No.: 630.7504 black



KTM 125 Duke

Item - No.: 4011.006.131 black

Assembling instructions

Fastening of the holding adapter:

Unscrew the two bolts (level with the turn signals) inside the fender.

Fix the holding adapter at these free threads with allen screws M6x45 with washers Ø6,4.

Sandwich steel spacer Ø10xØ7x7mm first, then alu spacer Ø18xØ7x20mm.

Do not tighten the screws completely.

1

driving direction 

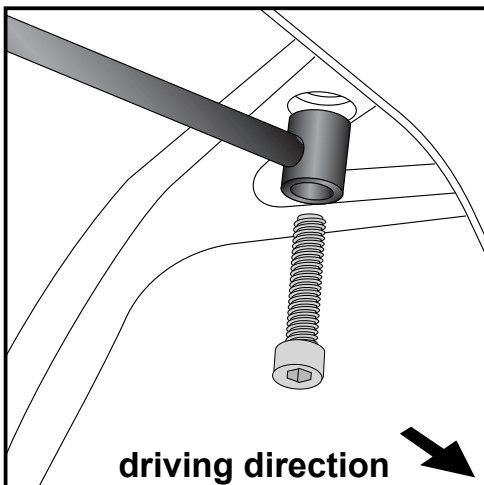
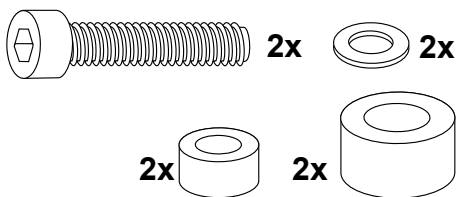
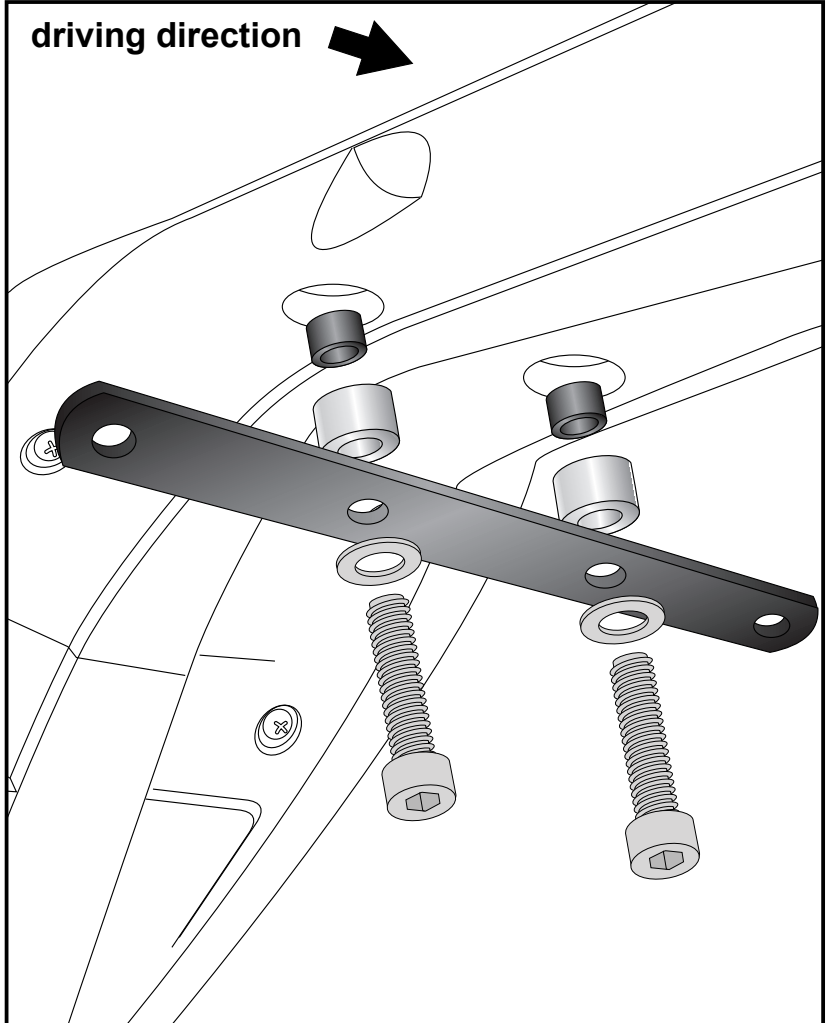

2

Fastening of the front adapters left and right:

Unscrew the rear bolt of the footrest bracket - screws are obsolete.

Fix the front adapters at these free threads with allen screws M8x40 with washers Ø8,4.

Do not tighten the screws completely.



C-Bow

KTM 125 Duke

Item - No.: 630.7504 black



KTM 125 Duke

Item - No.: 4011.006.131 black

Assembling instructions

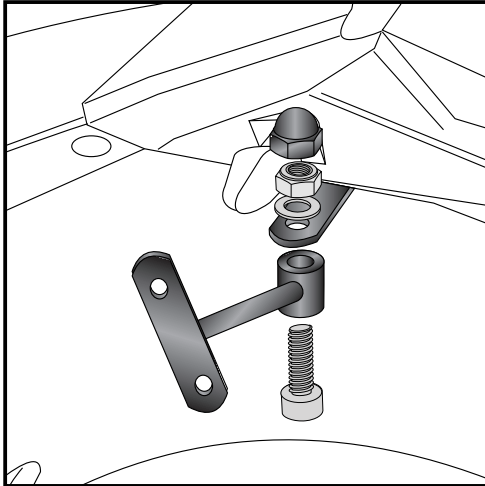

3

Fastening of the rear adapters left and right:

at the holding adapter, mounted in step 1.

Use allen screws M8x35.

Secure with washers Ø8,4 and self lock nuts M8.

Mount plastic caps to the nut.

Do not tighten the screws completely.

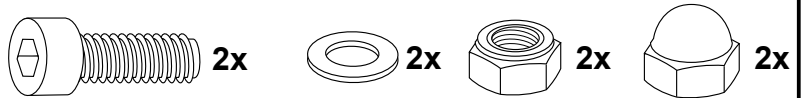

Fastening of the C-Bow:
with hexagon bolts M6 x 18 and
washers ø6,4.

Align all parts and tighten all screws.

4

