



KTM 790 Duke
Crash Protection

Installation Instructions



Kit Contents PRN013992

- | | |
|-----------------------------------|-------------------------------------|
| (A) 1 x L/H Main Bracket | (J) 1 x M12 x 95mm x 1.25 Caphead |
| (B) 1 x L/H Spacer (Long) | (K) 1 x Cross Support Bar |
| (C) 1 x L/H Cable Bracket | (L) 2 x M8 x 25mm Caphead |
| (D) 1 x R/H Main Bracket | (M) 2 x M10 x 35mm Caphead |
| (E) 1 x R/H Spacer (Short) | (N) 2 x M8 x 10mm Black Button Head |
| (F) 1 x R/H Cable Bracket | (O) 2 x M12 Washer |
| (G) 1 x M10 x 90mm Caphead | (P) 2 x Polyurathane Washer |
| (H) 1 x M10 x 75mm Caphead | (Q) 2 x Bobbin Heads |
| (I) 1 x M12 x 85mm x 1.25 Caphead | (R) 3 x Cable Ties |

K

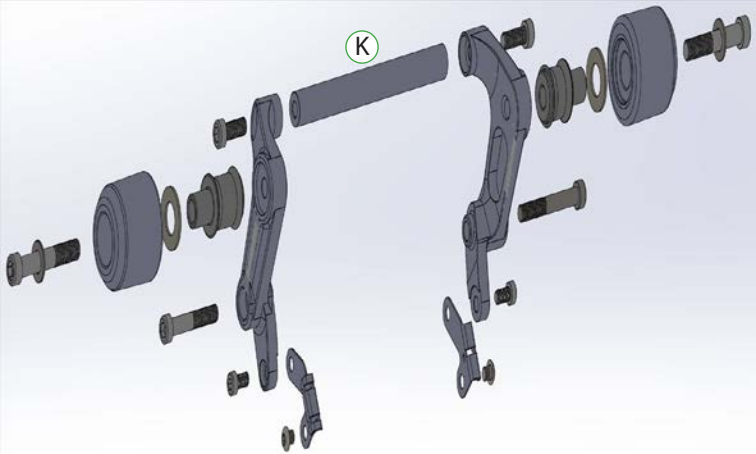

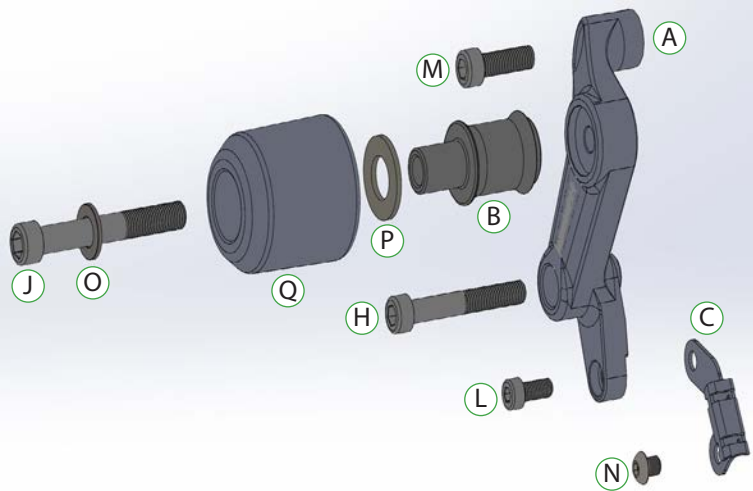

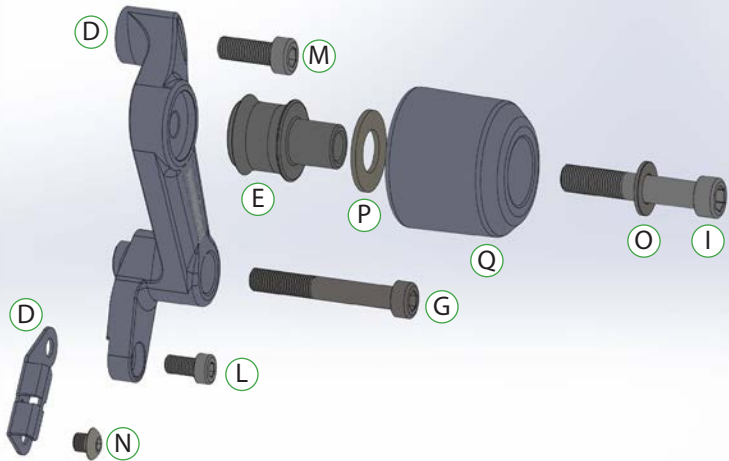

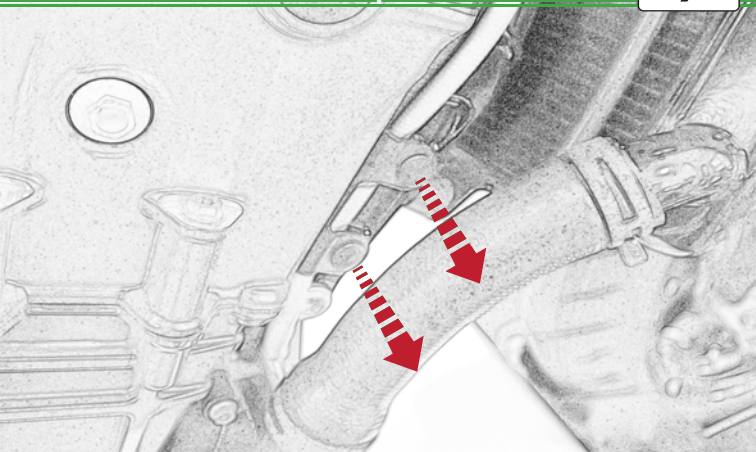

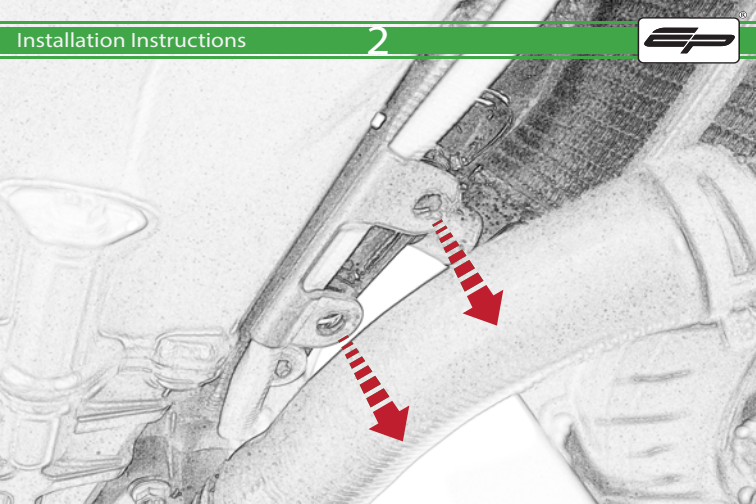

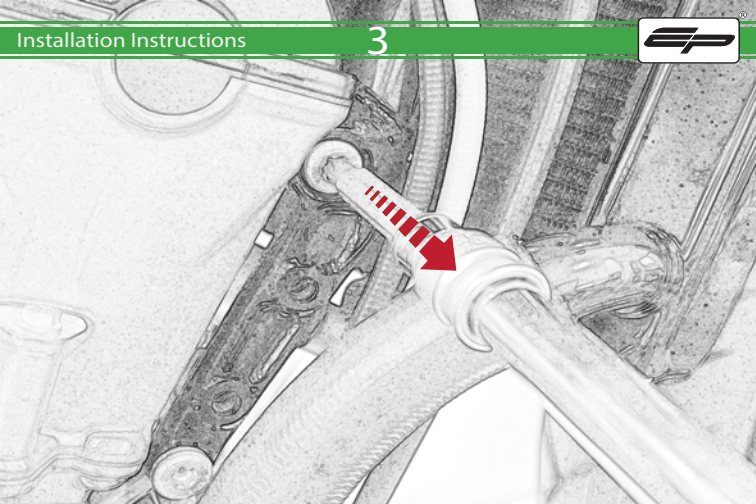

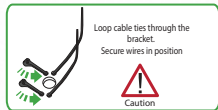
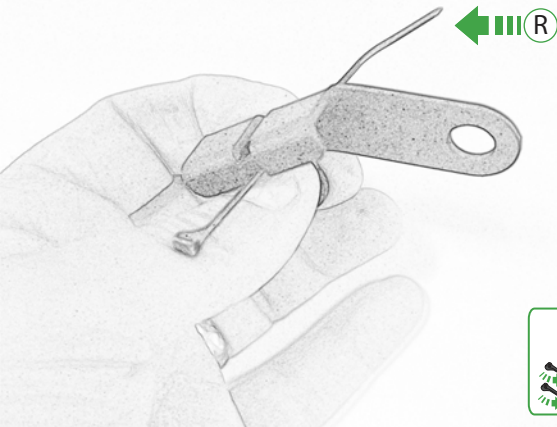

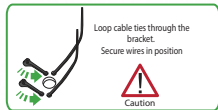
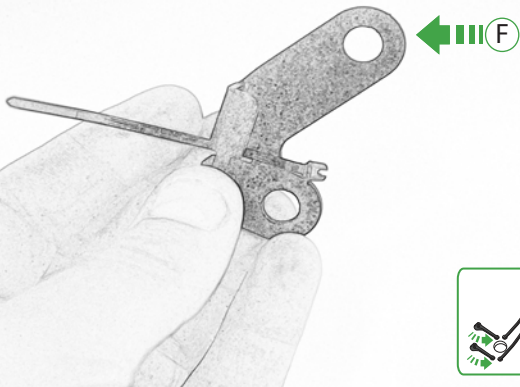

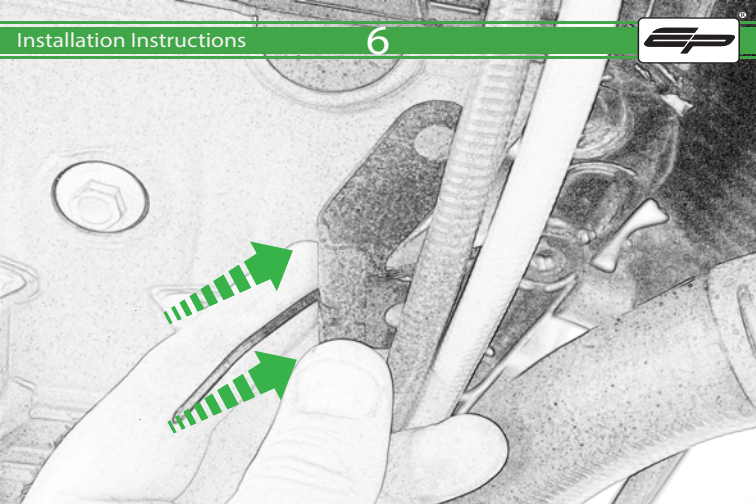

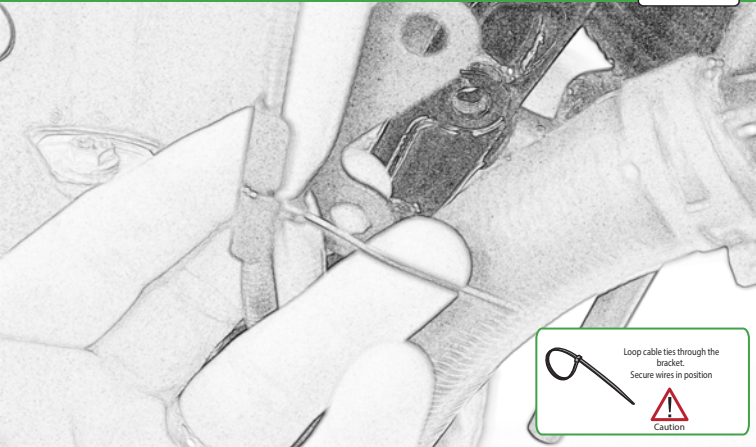

Loop cable ties through the bracket.
Secure wires in position



Caution

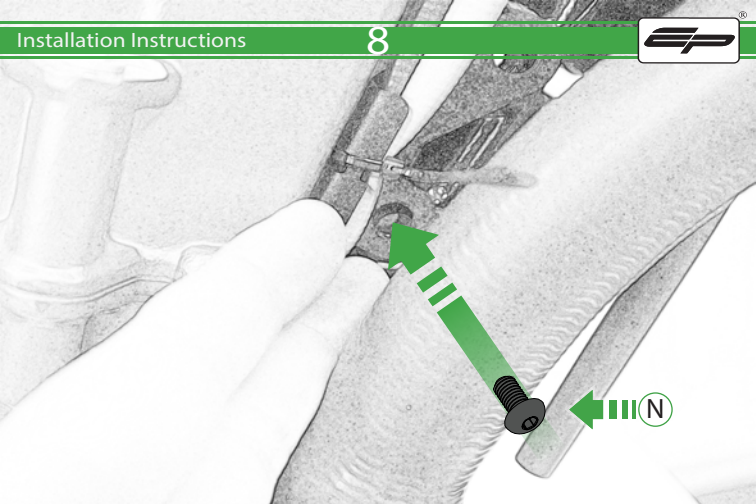

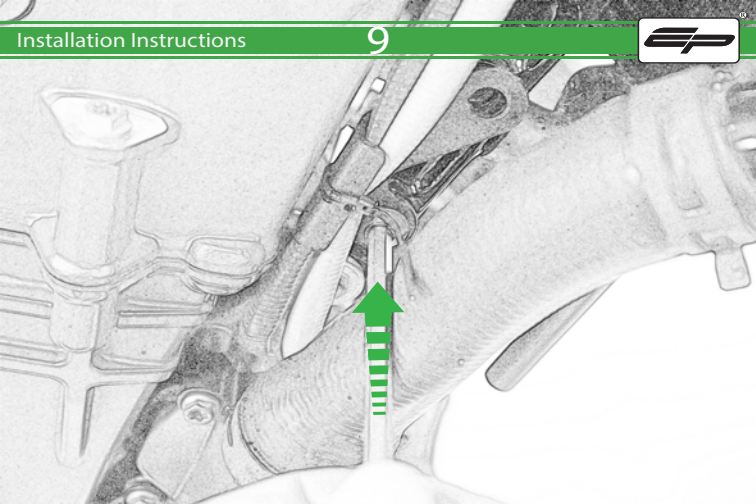

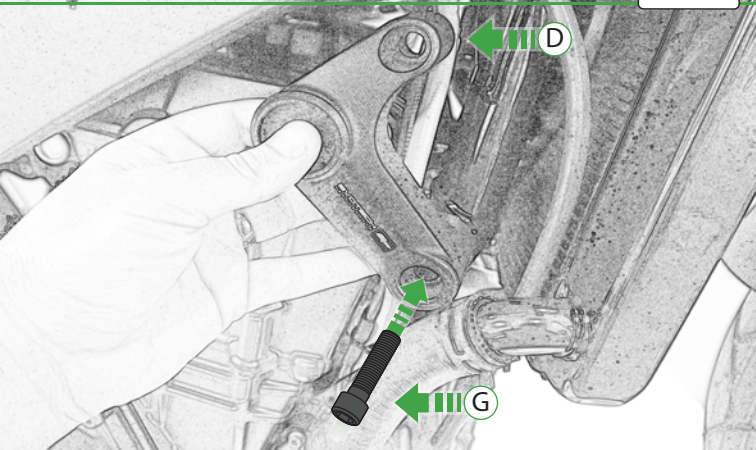

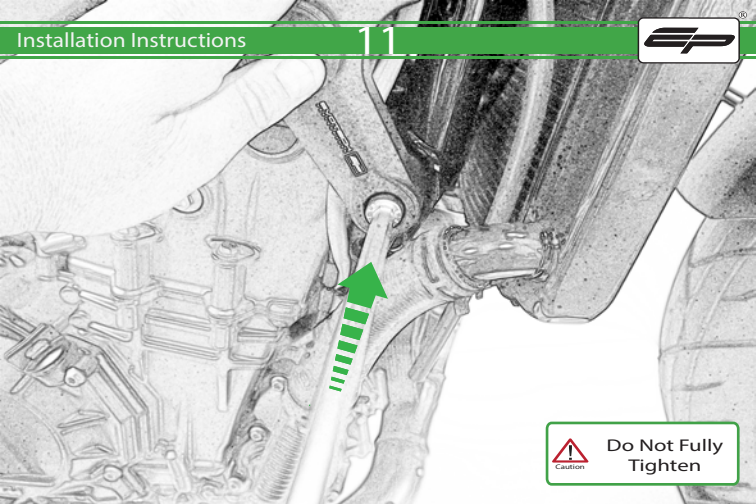

Do Not Fully Tighten

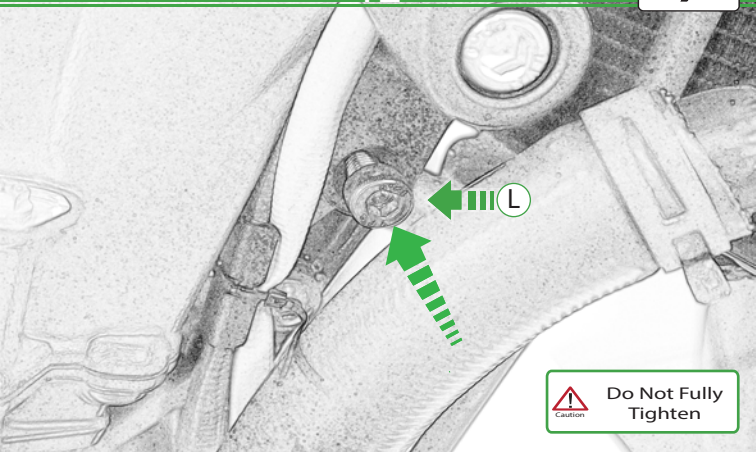

Caution

Do Not Fully Tighten

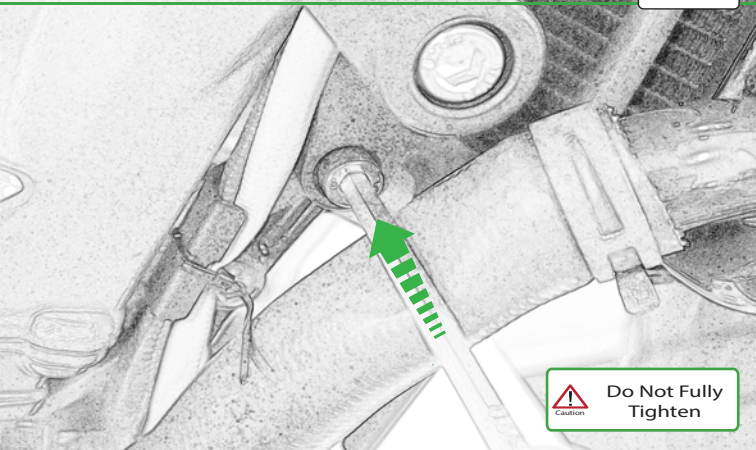

Do Not Fully Tighten

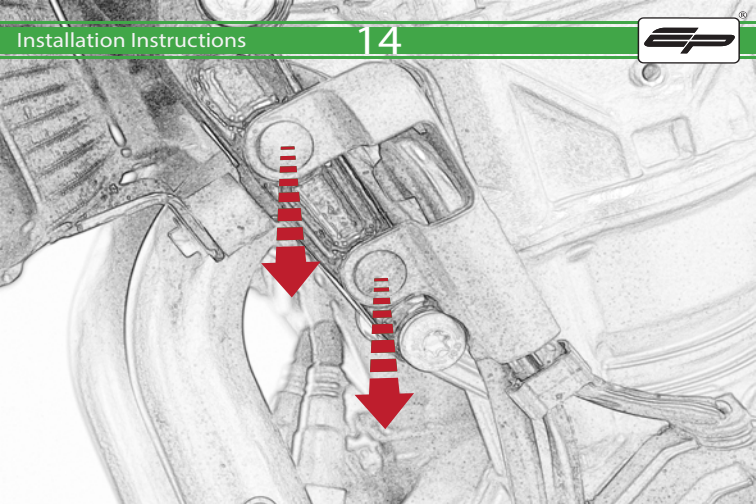

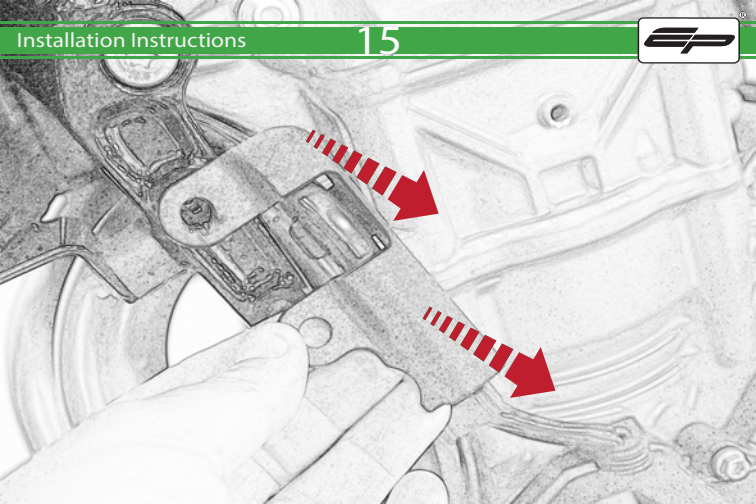

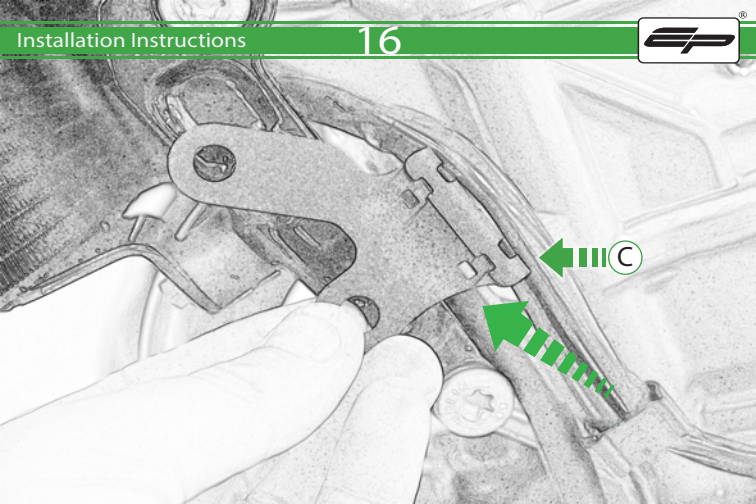

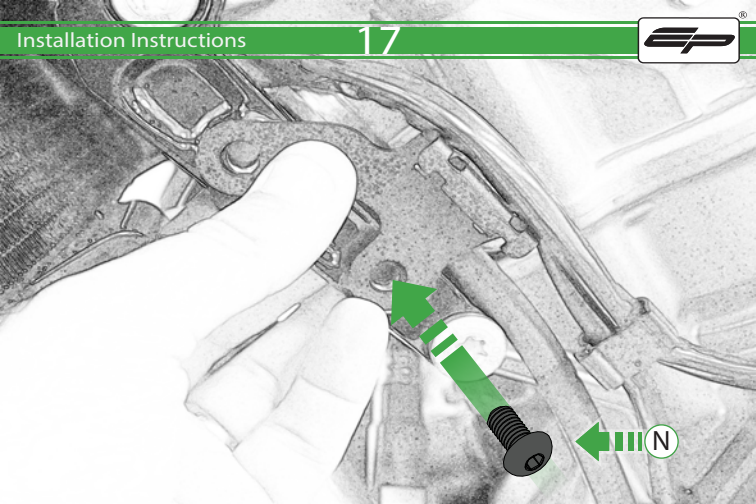

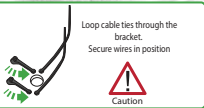

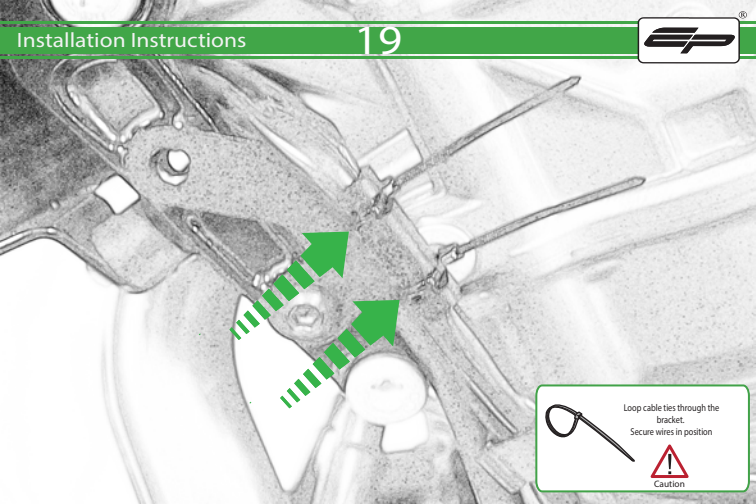

Loop cable ties through the bracket.

Secure wires in position



Caution

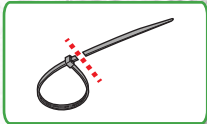
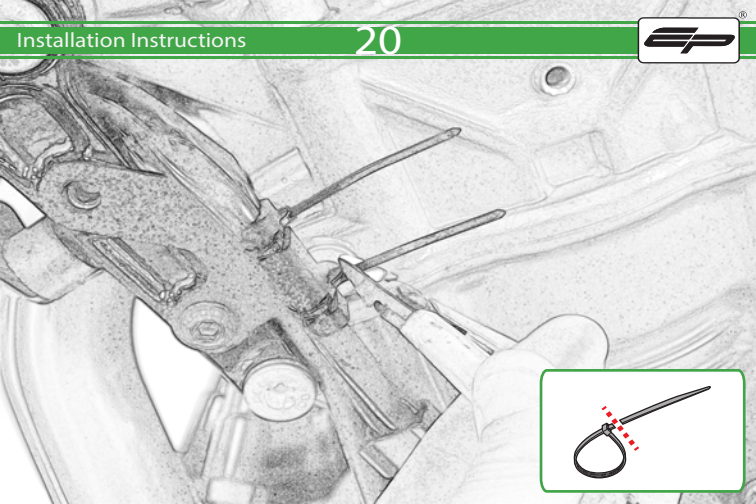

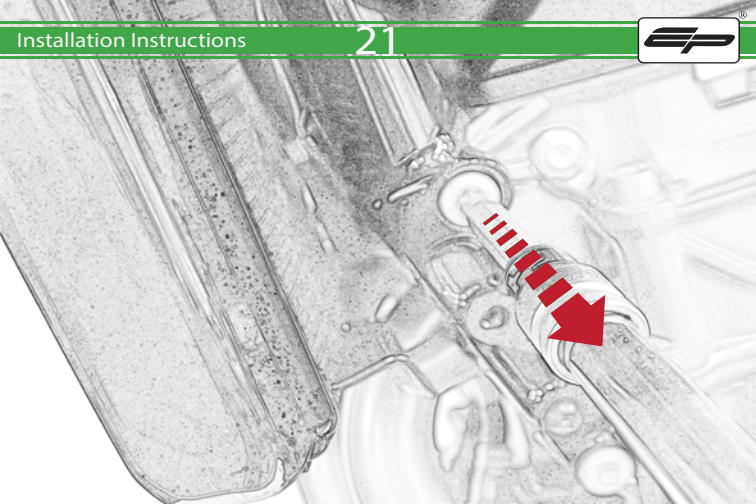

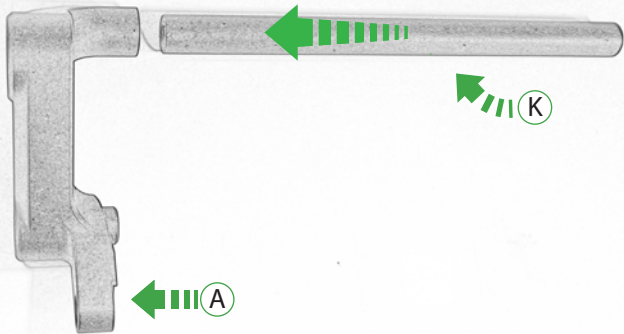

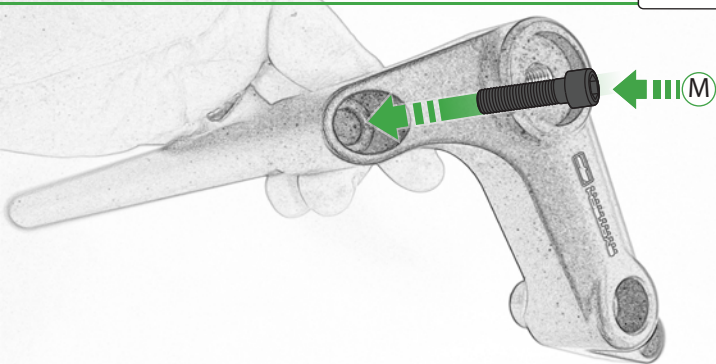

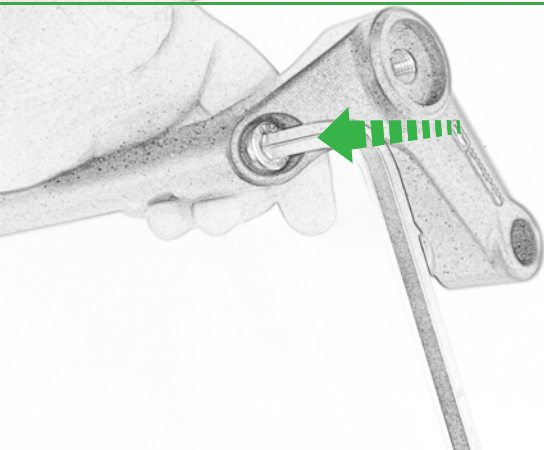



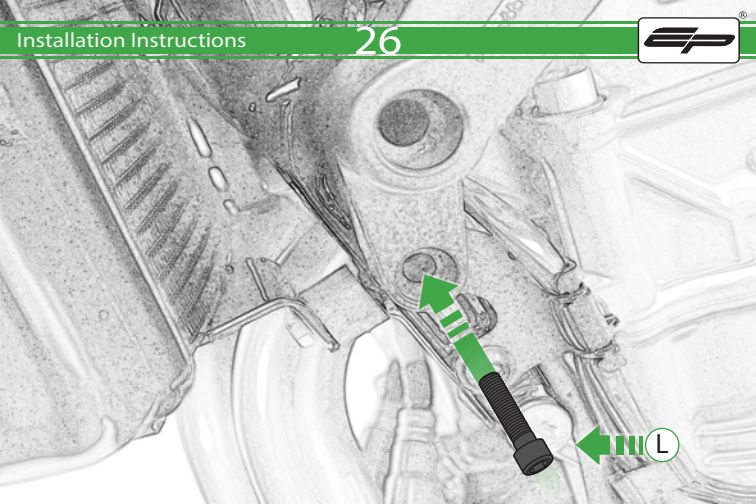

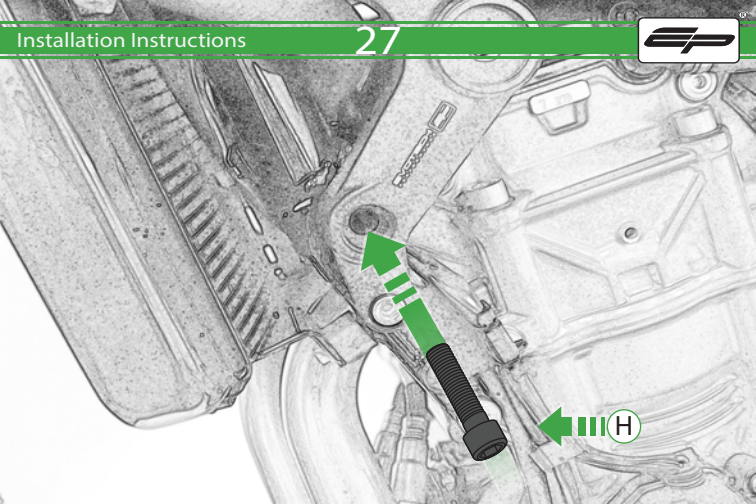



Fully
Tighten

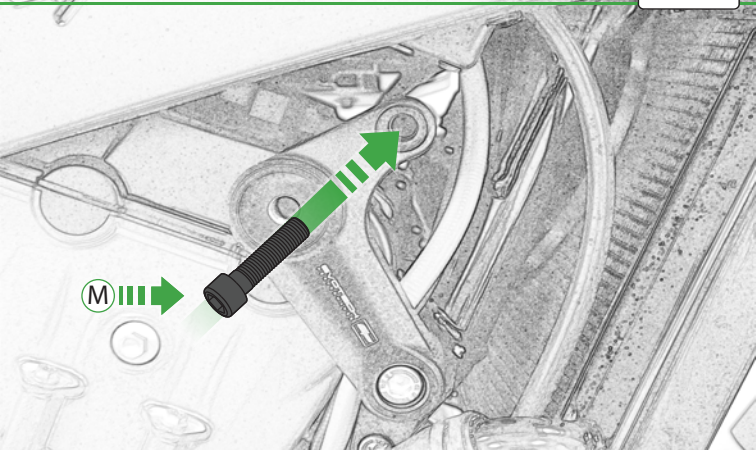

M

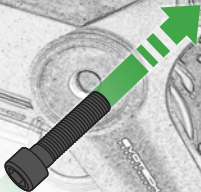

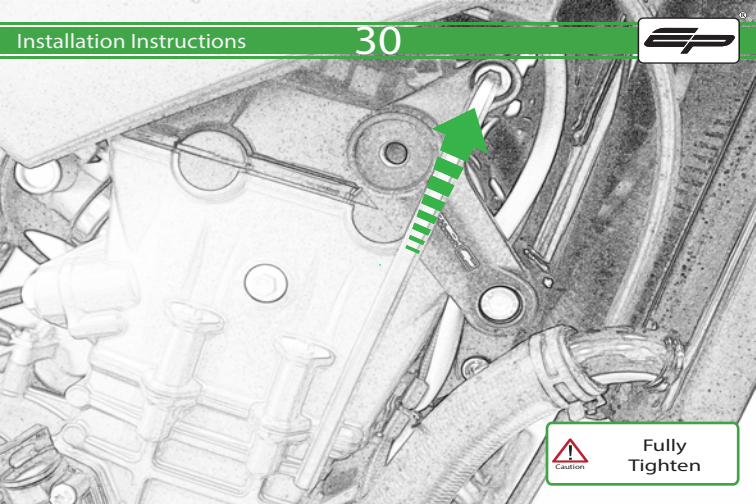

**Fully
Tighten**



Caution

Fully Tighten

A green-bordered box containing a warning icon (a triangle with an exclamation mark) and the word 'Caution' below it. To the right of the icon, the text 'Fully Tighten' is written in a bold, sans-serif font.

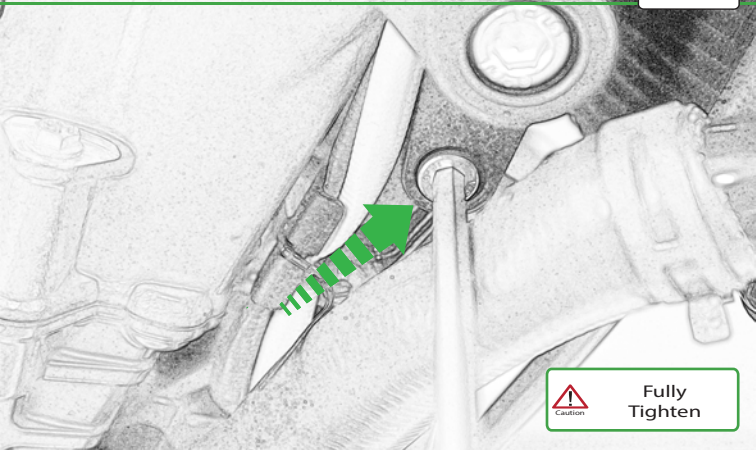

 **Fully Tighten**

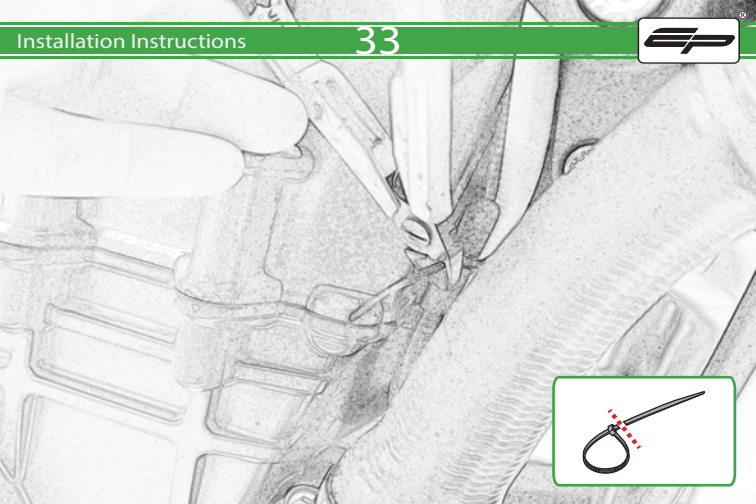

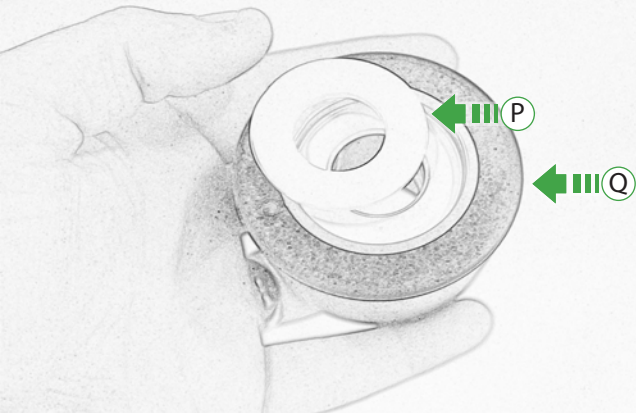

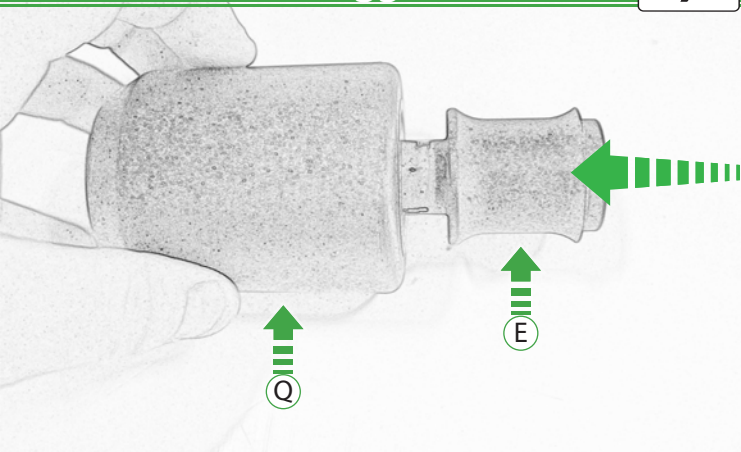



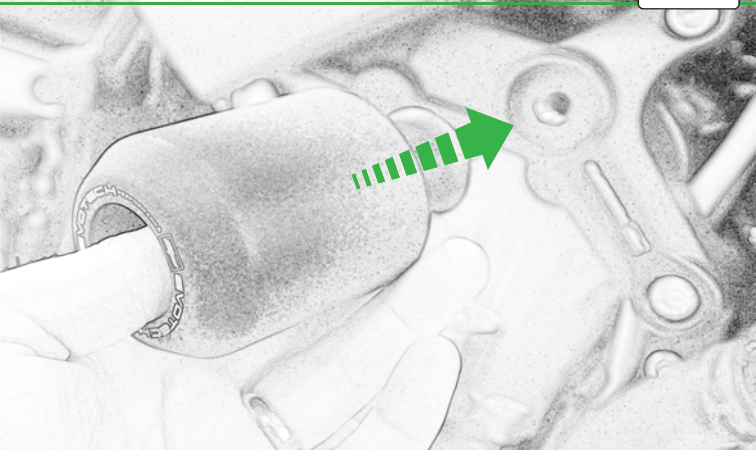



Fully
Tighten

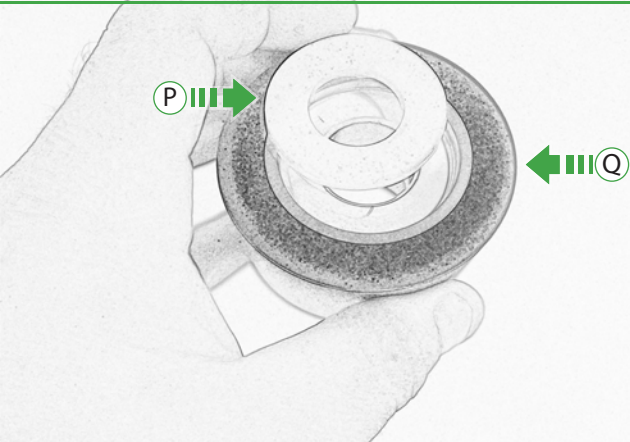

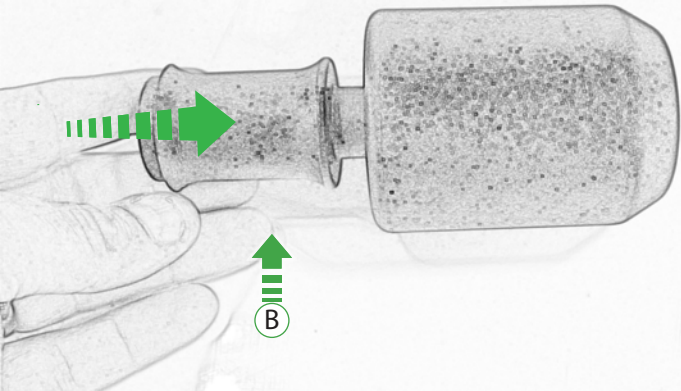

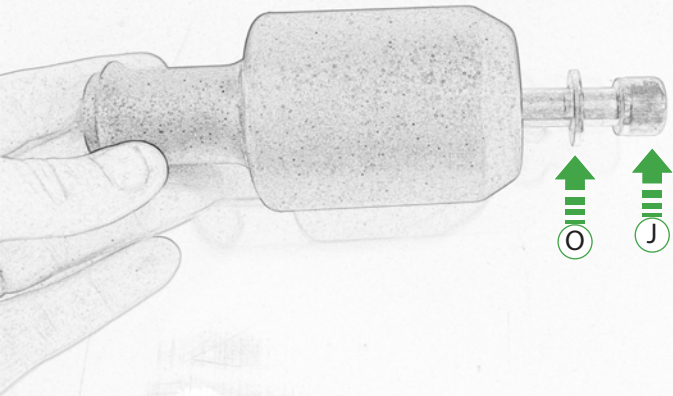



Fully
Tighten



Fully
Tighten

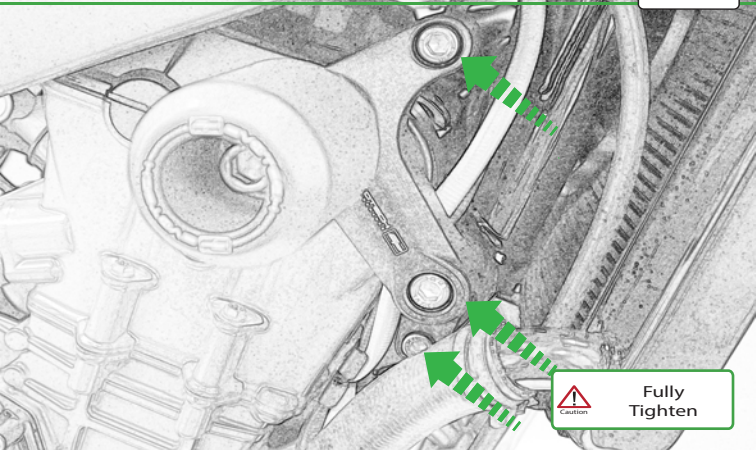

Fully
Tighten

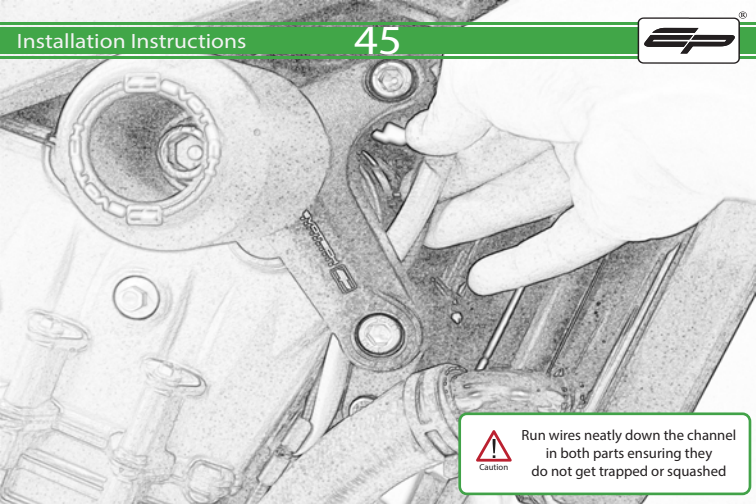

Run wires neatly down the channel in both parts ensuring they do not get trapped or squashed



 **ESSENTIAL CHECKS** 

It is recommended that periodic inspections are made to ensure that all bolts are tightened to the specified torque settings.

Should the bike be involved in an accident a thorough inspection should be made and any components that have taken an impact, no matter how small, be replaced



EVOTECH®
P E R F O R M A N C E

www.evotech-performance.com