

# Motorschutzbügel inkl. ProtectionPad



**KRAUSER**<sup>®</sup>  
MOTORRADGEPÄCKSYSTEME ■ BIKE BAGS

YAMAHA MT - 07

501.4537 00 05 anthrazit

YAMAHA MT - 07

3005.048.105 anthrazit

## Montage

Der Bausatz umfaßt die folgenden Teile:

Stück	Bestellnr.	Bezeichnung				
1	700008579	Motorschutzbügel links	1	507.001 ProtectionPad Set li/re, schwarz		
1	700008580	Motorschutzbügel rechts	bestehend aus:			
2	151.366	Inbusschrauben M12 x 140 x 1,25	1	Padkopf links	1	Padkopf rechts
4	150.783	Inbusschrauben M8 x 25	1	Polymerelement links	1	Polymerelement rechts
4	150.995	U-Scheiben ø8,4	1	Logo-Blende links	1	Logo-Blende rechts
			2	Hülse ø13 mm		



Als weiteres Zubehör lieferbar:  
Kofferträger (Lock it System, abnehmbar)  
Gepäckbrücke  
C-Bow Halter für Softtaschen  
Fußrasten Tieferlegung

**Anzugsmomente des Motorradherstellers beachten!**  
Nach der Montage alle Verschraubungen auf festen Sitz kontrollieren!  
Bitte beachten Sie unsere beigefügten Serviceinformationen.



**Hepco & Becker GmbH**  
An der Steinmauer 6  
D-66955 Pirmasens  
Tel.: 0049 6331 - 1453 - 100  
[www.hepco-becker.de](http://www.hepco-becker.de)



**Krauser GmbH**  
An der Steinmauer 6  
D-66955 Pirmasens  
Tel.: 0049 6331 - 1453 - 250  
[www.krauser.de](http://www.krauser.de)

YAMAHA MT - 07

501.4537 00 05 anthrazit

YAMAHA MT - 07

3005.048.105 anthrazit

## Montage

### Vorbereitung:

Der Protection Pad - Kopf muß vor der Befestigung am Halter zusammengebaut werden.

Zuerst die Hülse einsetzen. ①  
Anschließend das Polymerelement einschieben. ②

**Bitte Reihenfolge beachten!**

1

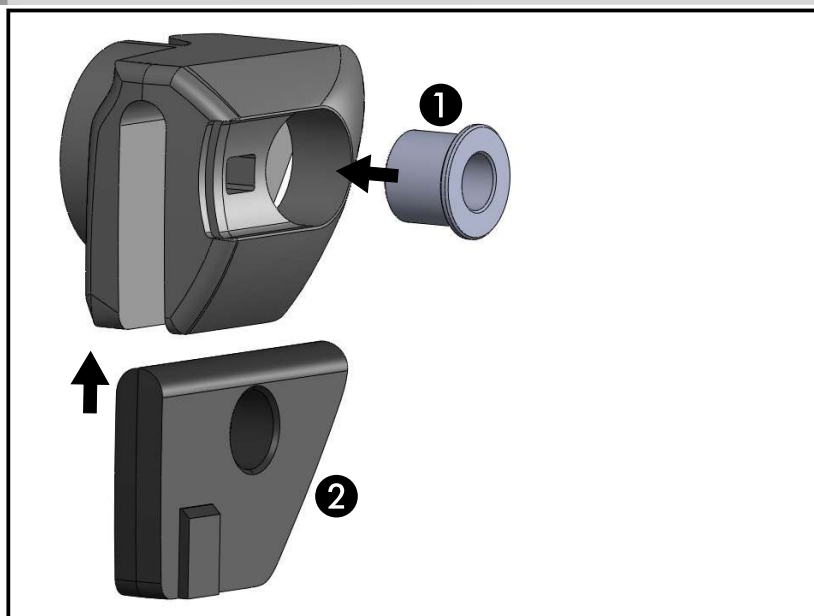

## RECHTE SEITE

### Vorbereitung Montage rechts:

Die Schrauben der vorderen Motoraufhängung ausdrehen.  
Die zwei Schrauben der mittleren Aufhängung am Rahmen ausdrehen.  
Die Originalschrauben entfallen.

### Montage hinten rechts:

Den Motorschutzbügel mit den Inbusschrauben M8x25 sowie U-Scheiben  $\varnothing 8,4$  verschrauben.

2

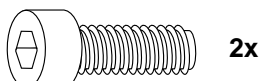
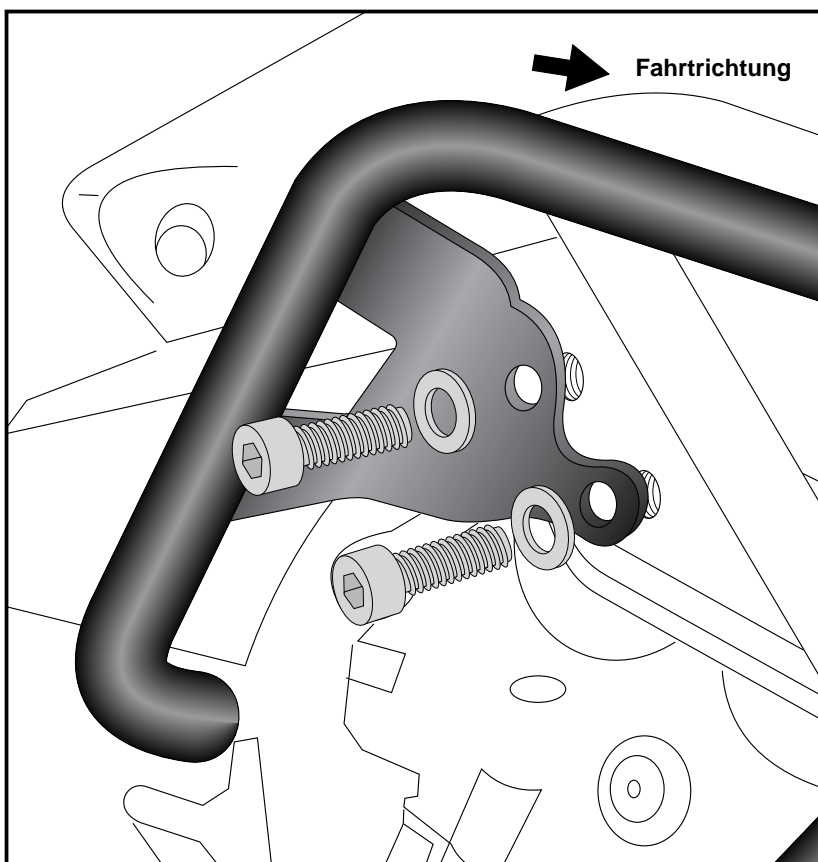



YAMAHA MT - 07

501.4537 00 05 anthrazit

YAMAHA MT - 07

3005.048.105 anthrazit

## Montage

### Montage vorne rechts:

Den Motorschutzbügel mit den Inbusschrauben M12 x 140 x 1,25 zusammen mit dem in Schritt 1 zusammengebauten ProtectionPad befestigen.

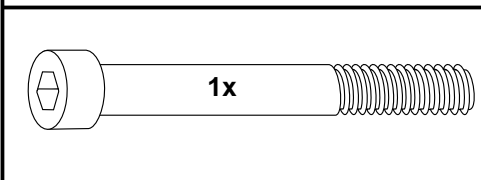

3

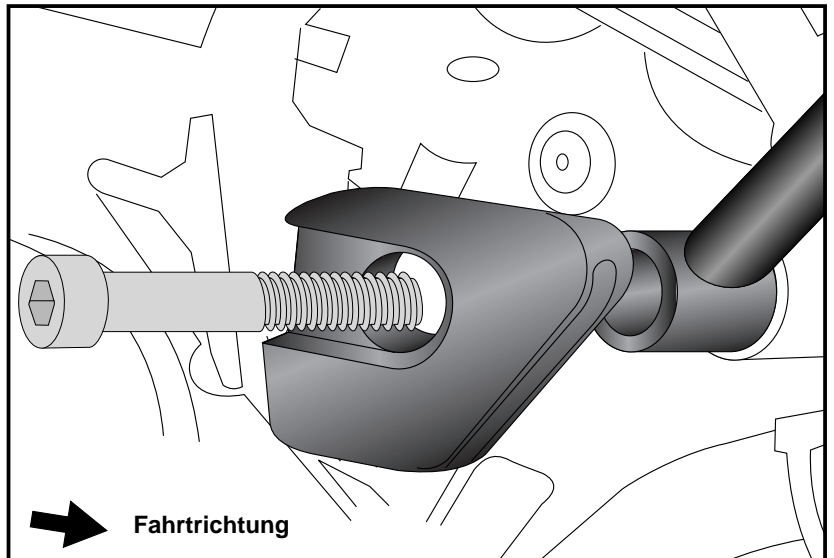

Nach abgeschlossener Montage die Logo-Blende einsetzen.

4

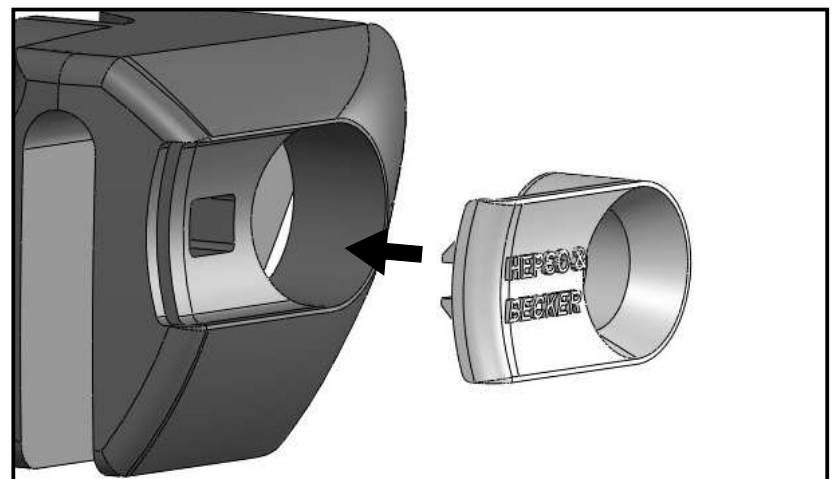

## LINKE SEITE

Befestigung Motorschutzbügel links:  
wie rechts

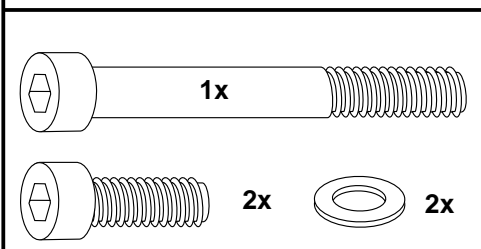

**Achtung ! Immer nur eine Seite nach der anderen montieren. Ansonsten besteht die Gefahr, dass sich der Motor absenkt.**

# Engine guard with ProtectionPad



**KRAUSER**<sup>®</sup>  
MOTORRADGEPÄCKSYSTEME ■ BIKE BAGS

YAMAHA MT - 07

501.4537 00 05 anthracite

YAMAHA MT - 07

3005.048.105 anthrazit

## Assembling instructions

The kit includes the following parts:

Quant	item no.	description	
1	700008579	engine guard left	
1	700005880	engine guard right	
2	151.366	allen screw M12 x 140 x 1,25	
4	150.783	allen screw M8 x 25	
4	150.995	washer ø 8,4	
1	507.001	ProtectionPad Set black	
included:			
1	Pad left	1	Pad right
1	Polymer element left	1	Polymer element right
1	cover left	1	cover right
2	spacer ø13 mm		



Also available:  
Side carrier (Lock it System, removable)  
Rear rack  
C-Bow Holder for softbags  
Footrest lowering set

**Control all screw connections after the assembling for tightness!  
Please notice our enclosed service information.**



**Hepco & Becker GmbH**  
An der Steinmauer 6  
D-66955 Pirmasens  
Tel.: 0049 6331 - 1453 - 100  
[www.hepco-becker.de](http://www.hepco-becker.de)



**Krauser GmbH**  
An der Steinmauer 6  
D-66955 Pirmasens  
Tel.: 0049 6331 - 1453 - 250  
[www.krauser.de](http://www.krauser.de)

# Engine guard with ProtectionPad



**KRAUSER**<sup>®</sup>  
MOTORRADGEPÄCKSYSTEME ■ BIKE BAGS

YAMAHA MT - 07

501.4537 00 05 anthracite

YAMAHA MT - 07

3005.048.105 anthrazit

## Assembling instructions

### Preparing:

The Protection Pad kit must be assembled before attaching the holder.

First insert the spacer. ①  
Then push in the polymer element. ②

**Please note the sequence !**

1

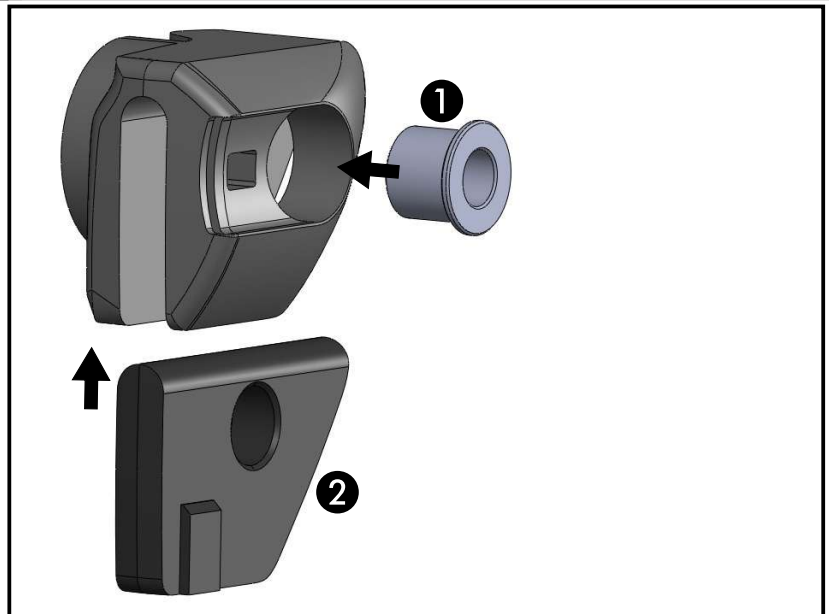

## RIGHT SIDE

### Preparing:

Unscrew the screws of the front engine mount and the two screws on the frame of the middle suspension.  
The original screws are obsolete.

Fastening of the engine guard rear right:  
with allen screws M8x25 and washers  
ø8,4.

2

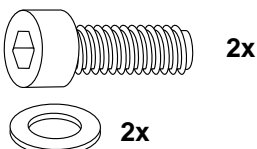
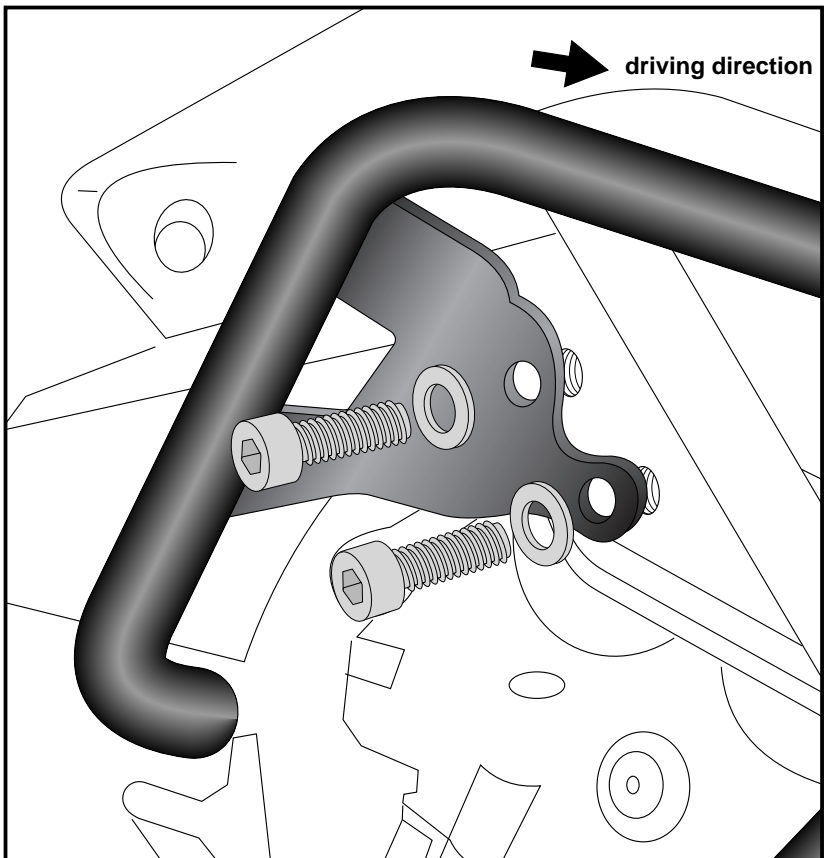

# Engine guard with ProtectionPad



**KRAUSER**<sup>®</sup>  
MOTORRADGEPÄCKSYSTEME ■ BIKE BAGS

YAMAHA MT - 07

501.4537 00 05 anthracite

YAMAHA MT - 07

3005.048.105 anthrazit

## Assembling instructions

**3** Fastening of the engine guard front right:  
with allen screws M12 x 140 x 1,25  
together with the prepared (step 1)  
ProtectionPads.

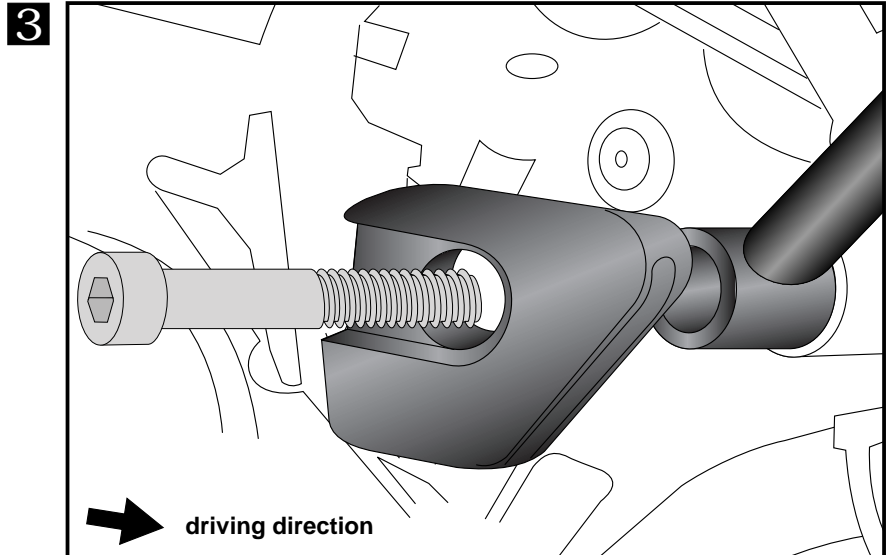
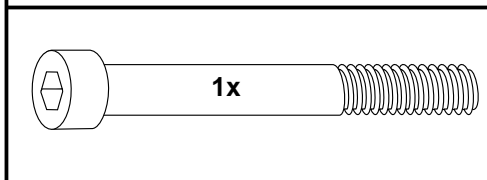

After finishing the mounting, insert the cover.

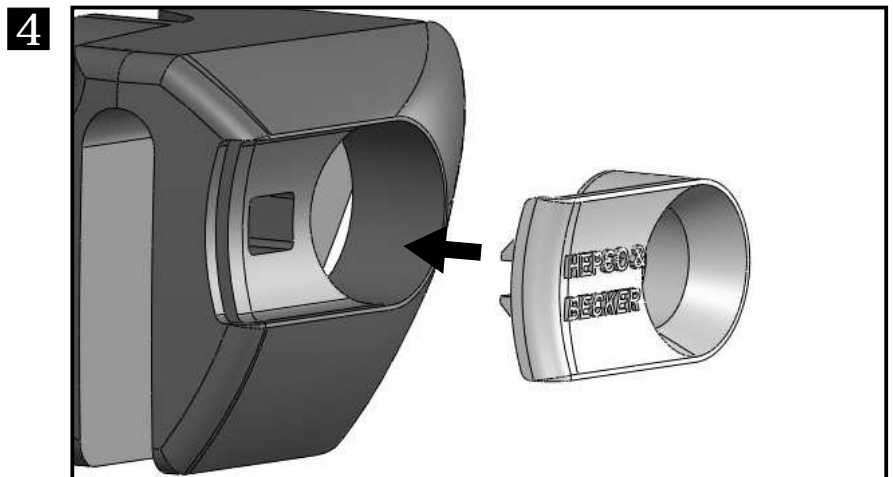

## LINKE SEITE

Fastening of the engine guard left:  
like right side

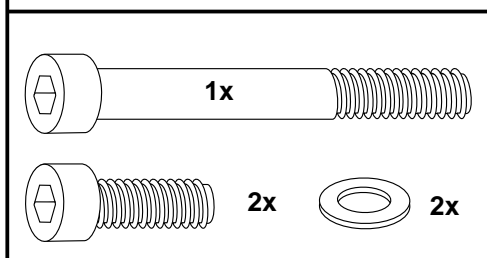

**Attention!**  
Mount one side after the other. Otherwise, there is the risk that the engine block change position.