

## Motorschutzbügel

YAMAHA XV 950 / R

Artikel-Nummer:  
501.4538 00 01 schwarz

Seitenkoffer  
Topcases  
Gepäckträger  
Lock it System  
Softbags  
Aluminiumkoffer  
Lederkoffer  
Schutzbügel  
Hauptständer  
Chopper-Parts  
Quad-Parts  
Accessoires



## Montage

### Der Bausatz umfaßt die folgenden Teile:

Stück	Bestellnr.	Bezeichnung			
1	700008479	Motorschutzbügel links	1	151.451	Inbusschrauben M12x270mm
1	700008480	Motorschutzbügel rechts	4	150.772	Inbusschrauben M6x65
2	151.450	Kunststoff-Klemmbackensatz Ø32 (mit Gewindeplatte)	1	151.098	Aludistanz Ø25xØ13x24mm
			2	151.110	U-Scheiben Ø12,5
			1	151.033	selbstsichernde Mutter M12
			4	150.809	U-Scheiben Ø6,4



### Anzugsmomente des Motorradherstellers beachten!

Nach der Montage alle Verschraubungen auf festen Sitz kontrollieren!  
Bitte beachten Sie unsere beigefügten Serviceinformationen.

### Weiteres lieferbares Zubehör:

C-Bow Packtaschenhalter Nr. 630.4538  
Sissybar mit Gepäckbrücke Nr. 6114538  
Solorack mit Rückenlehne Nr. 6114539

Lampenschutzgitter Nr. 7004538  
Sissybar ohne Gepäckbrücke Nr. 6004538  
Solorack ohne Rückenlehne Nr. 6004539



**Hepco & Becker GmbH**  
An der Steinmauer 6  
D-66955 Pirmasens

**Tel.: 06331 - 1453 - 100**  
**Fax: 06331 - 1453 - 120**  
**eMail: [vertrieb@hepco-becker.de](mailto:vertrieb@hepco-becker.de)**  
**[www.hepco-becker.de](http://www.hepco-becker.de)**

# Motorschutzbügel

YAMAHA XV 950 / R

Artikel-Nummer:  
501.4538 00 01 schwarz

- Seitenkoffer
- Topcases
- Gepäckträger
- Lock it System
- Softbags
- Aluminiumkoffer
- Lederkoffer
- Schutzbügel
- Hauptständer
- Chopper-Parts
- Quad-Parts
- Accessoires



## Montage

### Befestigung des Motorschutzbügels unten links:

An der unteren Motoraufhängung, Original Schraube entfällt. Die Befestigung erfolgt mit der Inbusschraube M12x270 sowie U-Scheibe Ø12,5.

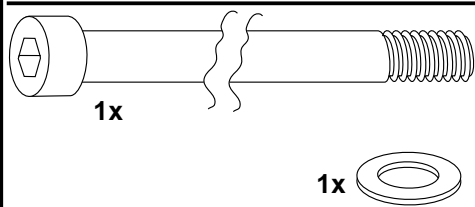

1

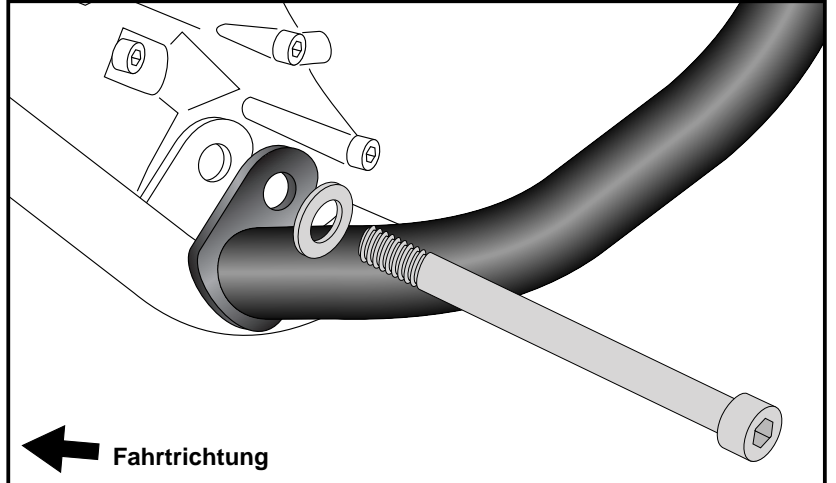

### Befestigung des Motorschutzbügels unten rechts:

Auf das überstehende Gewinde der Inbusschraube M12x270 die Aludistanz Ø25xØ13x24mm fügen und den rechten Motorschutzbügel mit der selbstsichernden Mutter M12 sowie U-Scheibe Ø12,5 montieren.

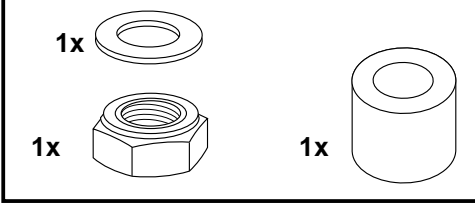

2

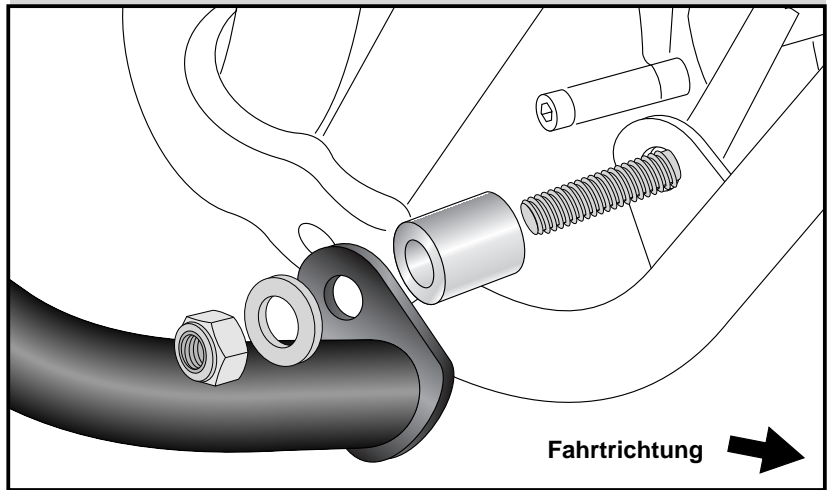

### Befestigung des Motorschutzbügels oben links und rechts:

Die untere Befestigung des Kabels zur Hupe lösen. Am Rahmen mit den Kunststoff-Klemmbacken Ø 32 inkl. Gewindeplatten M6 und den Inbusschrauben M6x65 sowie U-Scheiben Ø6,4 befestigen.

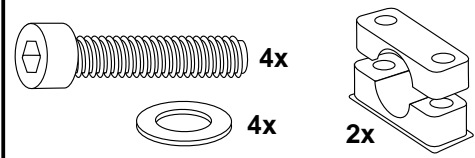

3

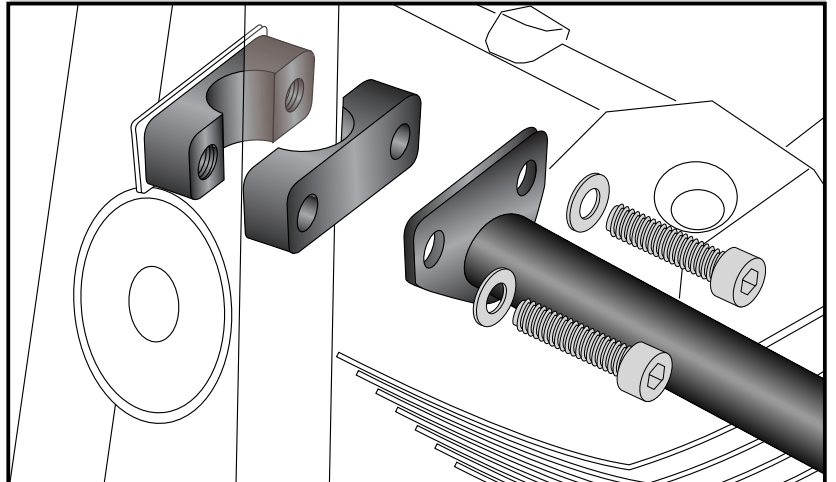

## Engine guard

YAMAHA XV 950 / R

Item-no.:  
501.4538 00 01 black

Side cases  
Top cases  
luggage frames  
Lock it system  
Softbags  
Aluminium luggage  
Leather luggage  
Protection bars  
Center stands  
Chopper parts  
Quad parts  
Accessories



### Assembling instructions

The kit includes the following parts:

Quant	item no.	description			
1	700008479	engine guard left	1	151.451	allen screw M12x270mm
1	700008480	engine guard right	4	150.772	allen screw M6x65
2	151.450	frame adapter Ø32 (with threaded plate)	1	151.098	alu spacer Ø25xØ13x24mm
			2	151.110	washer Ø12,5
			1	151.033	self-nock nut M12
			4	150.809	washer Ø6,4



**Control all screw connections after the assembling for tightness!  
Please notice our enclosed service information.**

**Also available:**

C-Bow leather bag holder No. 630.4538  
Sissybar with rear rack No. 6114538  
Solorack with back rest No. 6114539

Headlight grilles No. 7004538  
Sissybar without rear rack No. 6004538  
Solorack without back rest No. 6004539



**Hepco & Becker GmbH**  
An der Steinmauer 6  
D-66955 Pirmasens  
Germany

**Tel.: +49 6331 - 1453 - 100**  
**Fax: +49 6331 - 1453 - 120**  
**eMail: [vertrieb@hepco-becker.de](mailto:vertrieb@hepco-becker.de)**  
**[www.hepco-becker.de](http://www.hepco-becker.de)**

# Engine guard

YAMAHA XV 950 / R

Item-no.:  
501.4538 00 01 black

- Side cases
- Top cases
- luggage frames
- Lock it system
- Softbags
- Aluminium luggage
- Leather luggage
- Protection bars
- Center stands
- Chopper parts
- Quad parts
- Accessories



## Assembling instructions

### Fastening of the engine guard bottom left:

to the lower engine mount - original screw is obsolete. Use allen screw M12x270 with  $\text{Ø}12,5$ .

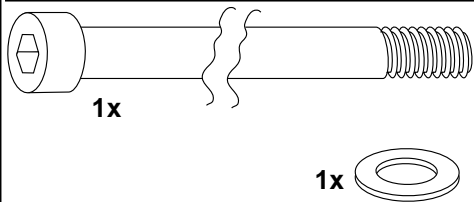

1

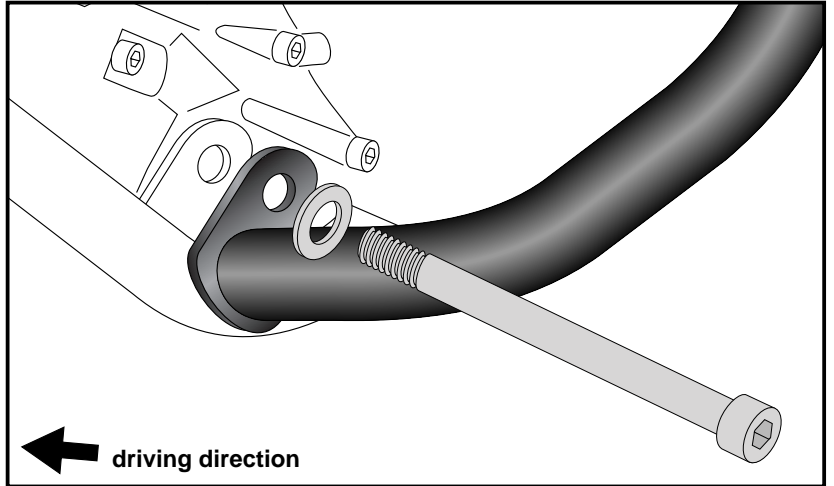

### Fastening of the engine guard bottom right:

add the alu spacer  $\text{Ø}25 \times \text{Ø}13 \times 24\text{mm}$  on the exposed threads of the allen screw M12x270 and install the right engine guard with the self-lock nut M12 and washer  $\text{Ø}12,5$ .

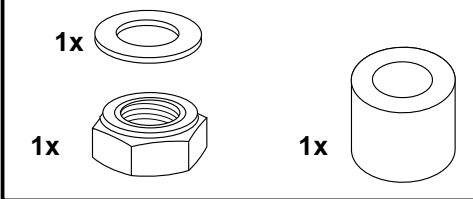

2

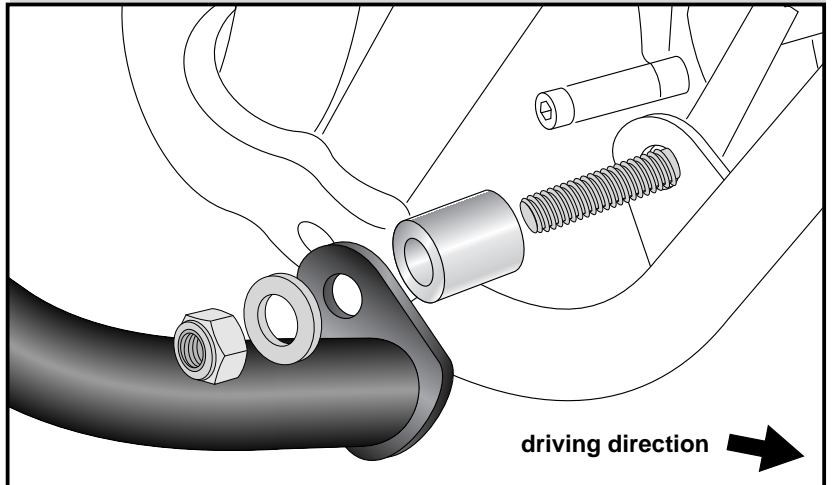

### Fastening of the engine guard top left + right:

Loosen the lower mounting of the cable to the horn. Fix the engine guard with the frame adapters and the threaded plates to the frame. Fo fix, use allen screws M6x65 with washers  $\text{Ø}6,4$ .

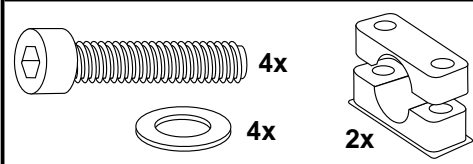

3

