

Motorschutzbügel Triumph Thunderbird 1600

Artikel-Nummer:
501.720 00 02 chrom

Seitenkoffer
Topcases
Gepäckträger
Lock it System
Softbags
Aluminiumkoffer
Lederkoffer
Schutzbügel
Hauptständer
Chopper-Parts
Quad-Parts
Accessoires



Montage

Stück	Bestellnr.	Bezeichnung
1	708.504HB	Motorschutzbügel links
1	708.505HB	Motorschutzbügel rechts
1	150.938	Linienkopfschraube M8 x 20
2	150.783	Inbusschraube M8 x 25
2	150.865	Inbusschraube M10 x 30
4	150.811	U-Scheibe ø10,5
3	150.810	U-Scheibe ø8,4
2	150.801	Selbstsichernde Mutter M10
2	151.264	Alu-Distanz Ø25xØ9x7mm
1	151.116	Alu-Distanz Ø18xØ9x5mm



rechte Seite

Anzugsmomente des Motorradherstellers beachten!
Nach der Montage alle Verschraubungen auf festen Sitz kontrollieren!
Bitte beachten Sie unsere beigefügten Serviceinformationen.

Weiteres lieferbares Zubehör:

Sissybar mit Gepäckbrücke Nr. 611.720 00 02 chrom
Packtaschenhalter C-Bow Nr. 630.720 00 02 chrom



Heppo & Becker GmbH
An der Steinmauer 6

D-66955 Pirmasens

Tel.: 06331 - 1453 - 100
Fax: 06331 - 1453 - 120
eMail: vertrieb@heppo-becker.de
www.heppo-becker.de

Motorschutzbügel
Triumph Thunderbird 1600

Artikel-Nummer:
501.720 00 02 chrom

Seitenkoffer
Topcases
Gepäckträger
Lock it System
Softbags
Aluminiumkoffer
Lederkoffer
Schutzbügel
Hauptständer
Chopper-Parts
Quad-Parts
Accessoires



Montage

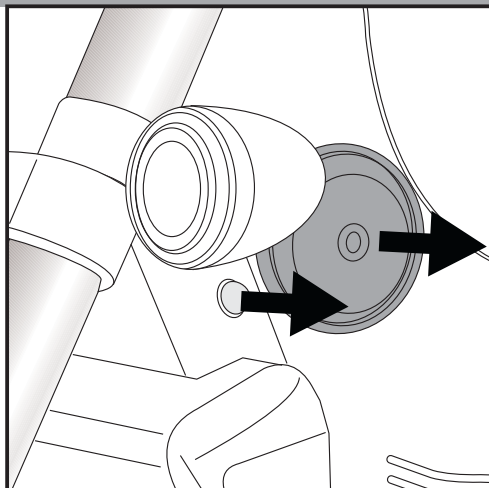

1

Vorbereitung:

- Blindstopfen am Rahmen oberhalb des Kühlers entfernen. Sie entfallen!
- Hupe demontieren (wird wieder montiert)

Montage der Motorschutzbügel
links und rechts:

Bügelhälften rechts und links über den Verschraubungspunkten am Rahmen und der Fußrastenaufnahmen positionieren.

Alu-Distanz $\varnothing 25 \times \varnothing 9 \times 7\text{mm}$ zwischen den oberen Sturzbügellaschen und Rahmen positionieren und handfest mit den Inbusschrauben M8x25 sowie den U-Scheiben $\varnothing 8,4$ verschrauben.

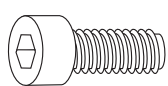

2x



2x



2x

2

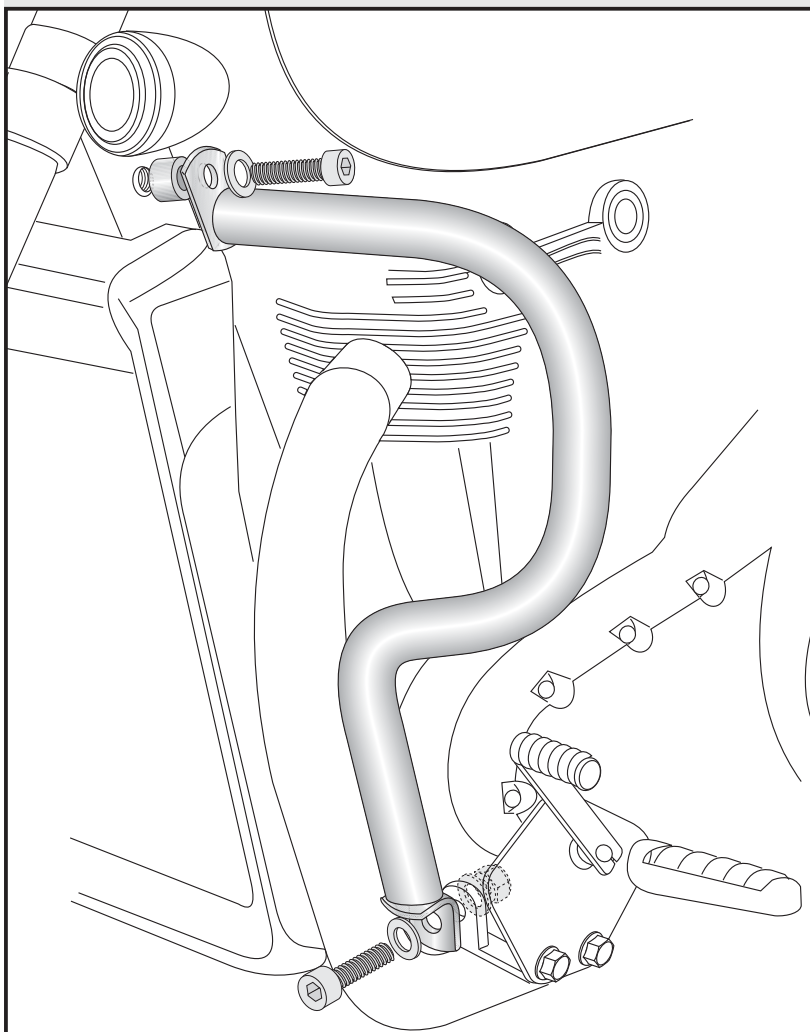

Für die unteren Verschraubungspunkte verwenden Sie die Inbusschrauben M10x30, die U-Scheiben $\varnothing 10,5$ sowie die selbstsichernden Muttern M10.

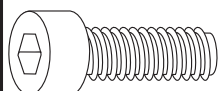

2x

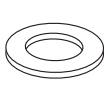

4x



2x

Motorschutzbügel
Triumph Thunderbird 1600

Artikel-Nummer:
501.720 00 02 chrom

Seitenkoffer
Topcases
Gepäckträger
Lock it System
Softbags
Aluminiumkoffer
Lederkoffer
Schutzbügel
Hauptständer
Chopper-Parts
Quad-Parts
Accessoires



Montage

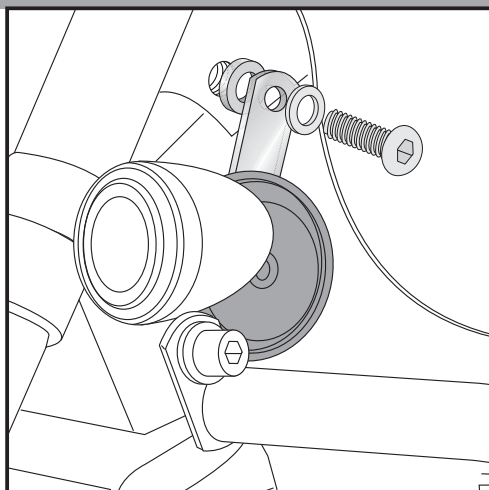

3

Montage der Hupe:

Montieren Sie die Hupe wieder mit der mitgelieferten Alu-Distanz $\varnothing 18 \times \varnothing 9 \times 5\text{mm}$, der Linsenkopfschraube M8x20 sowie der U-Scheibe $\varnothing 8,4$.

Jetzt alle Verschraubungen kontrollieren und Schrauben anziehen.

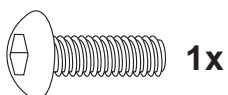

1x



1x



1x

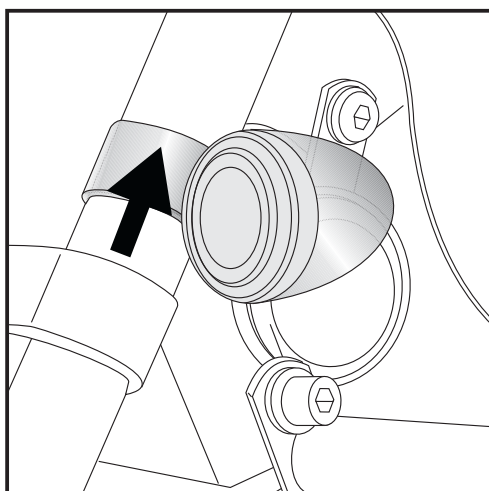

4

Blinker verschieben:

Lösen Sie die Klemmung der vorderen Blinker und schieben diese 30mm nach oben und ziehen die Klemmungen wieder an. Lenkeinschlag prüfen.

Engine guard
Triumph Thunderbird 1600

Item-No.
501.720 00 02 chrome

Side cases
Top cases
luggage frames
Lock it system
Softbags
Aluminium luggage
Leather luggage
Protection bars
Center stands
Chopper parts
Quad parts
Accessories



Assembling instructions

The kit includes the following parts:

Quant	item no.	description
1	708.504HB	engine guard left
1	708.505HB	engine guard right
1	150.938	filister head screw M8 x 20
2	150.783	allen screw M8 x 25
2	150.865	allen screw M10 x 30
4	150.811	washer \varnothing 10,5
3	150.810	washer \varnothing 8,4
2	150.801	self-lock nut M10
2	151.264	spacer \varnothing 25x \varnothing 9x7mm
1	151.116	spacer \varnothing 18x \varnothing 9x5mm



right side

Control all screw connections after the assembling for tightness! Please notice our enclosed service information. All screws, bolts and nuts should be checked after driving the first 50 km to ensure that all are tightened to the proper torque. Medium strength liquid thread-locker (i.e., „Locktite“) should be used to secure all screws, bolts, and nuts.

Also available:

Sissybar with rear rack Nr. 611.720 00 02 chrome
Leather bag holder C-Bow Nr. 630.720 00 02 chrome



Hepco & Becker GmbH
An der Steinmauer 6
D-66955 Pirmasens
Germany

Tel.: +49 6331 - 1453 - 100
Fax: +49 6331 - 1453 - 120
eMail: vertrieb@hepco-becker.de
www.hepco-becker.de

Engine guard
Triumph Thunderbird 1600

Item-No.
501.720 00 02 chrome

- Side cases
- Top cases
- luggage frames
- Lock it system
- Softbags
- Aluminium luggage
- Leather luggage
- Protection bars
- Center stands
- Chopper parts
- Quad parts
- Accessories



Assembling instructions

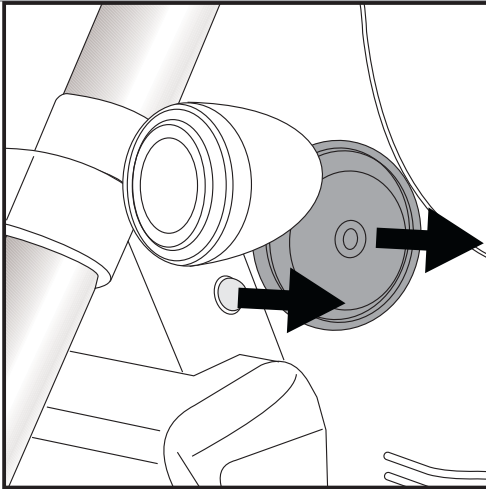

1

Preparing:
Left + right side: dismantle plugs in the frame borings above cooler - they are obsolete

Dismantle horn.

Fastening of the crash bars left+right:
Sandwich spacer $\varnothing 25 \times \varnothing 9 \times 7\text{mm}$
between crash bar and the frame and
mount it with allen screws M8 x 25 and
washers $\varnothing 8,4$.
Do not tighten the screws !

2

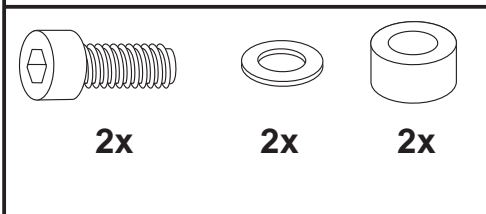
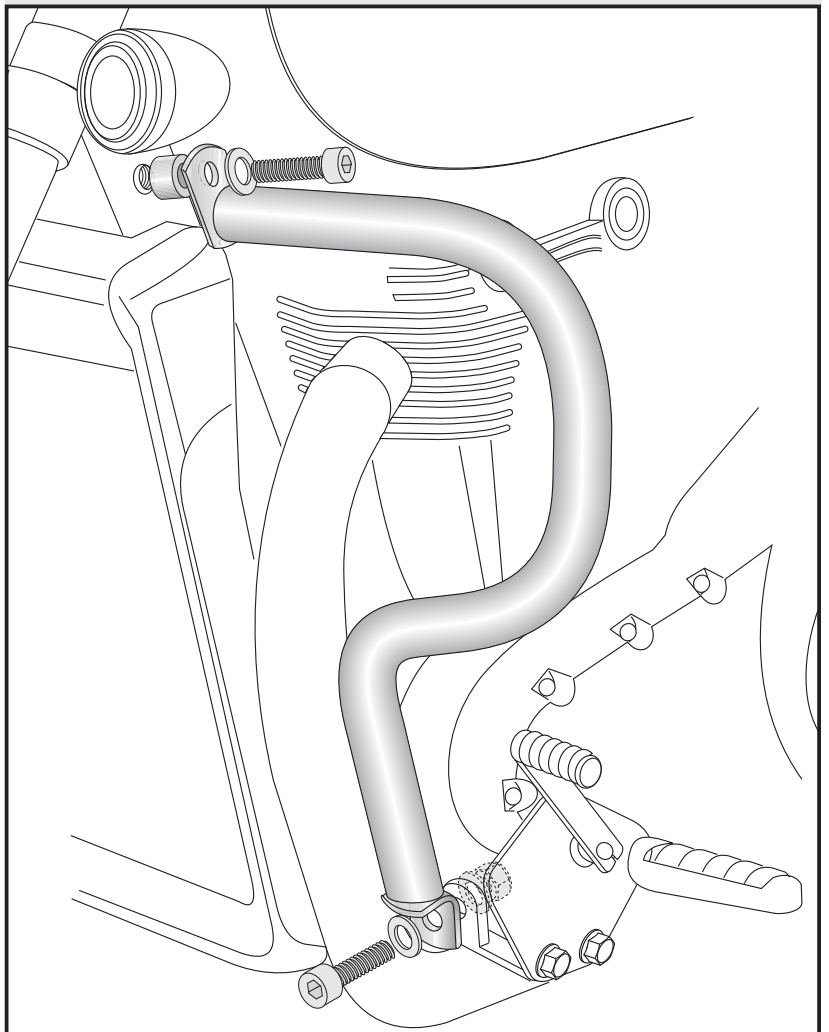

At the bottom fixing points use allen
screws M10x30, washers $\varnothing 10,5$ and self-
lock nuts M10.

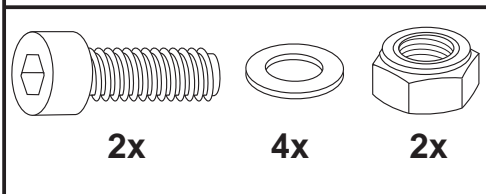

Engine guard
Triumph Thunderbird 1600

Item-No.
501.720 00 02 chrome

Side cases
Top cases
luggage frames
Lock it system
Softbags
Aluminium luggage
Leather luggage
Protection bars
Center stands
Chopper parts
Quad parts
Accessories



Assembling instructions

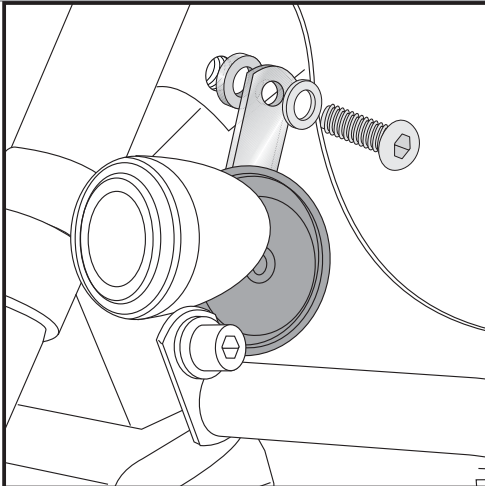

3

Fastening of the horn:

Mount the original horn again.

Sandwich spacer $\varnothing 18 \times \varnothing 9 \times 5\text{mm}$.

To fix, use filister head screw M8x20 and washer $\varnothing 8,4$.

Now tighten all the screws.

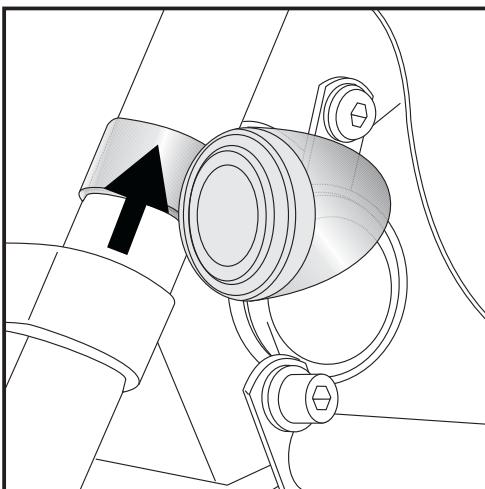
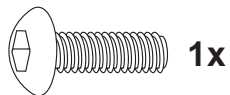

4

Change position of the blinkers:

it is necessary to lift the position of the blinkers for 30mm.

Control correct movement of the handle bar.