

## Motorschutzbügel

HONDA CBF 600 ab 2008  
Art.Nr.:501.953 00 01 schwarz

Seitenkoffer  
Topcases  
Gepäckträger  
Lock it System  
Softbags  
Aluminiumkoffer  
Lederkoffer  
Schutzbügel  
Hauptständer  
Chopper-Parts  
Quad-Parts  
Accessoires



## Montageanleitung

Der Bausatz umfaßt die folgenden Teile:

Stück	Bestellnr.	Bezeichnung
1	701.515HB	Motorschutzbügel links
1	701.516HB	Motorschutzbügel rechts
2	150.850	Sechskantschrauben M 10 x 25
4	150.811	U-Scheiben $\varnothing$ 10,5 mm
2	150.801	selbstsichernde Muttern M 10
1	151.059	Stiftschraube M6 x 10

## rechte Seite

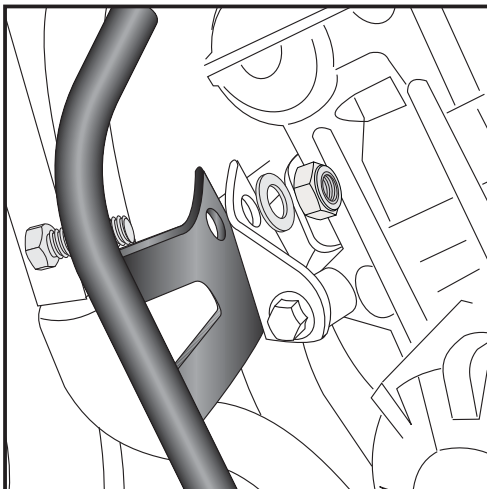
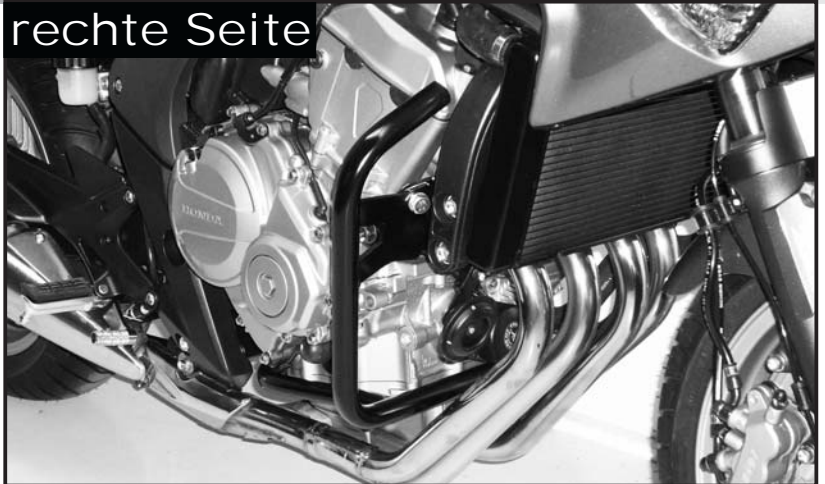

1

### Befestigung links oben:

An der freien Bohrung der vorderen Motoraufhängung mit den Sechskantschrauben M 10 x 25 sowie U-Scheiben  $\varnothing$ 10,5 und selbstsichernder Mutter M10.

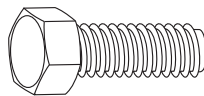

1x

2x



1x

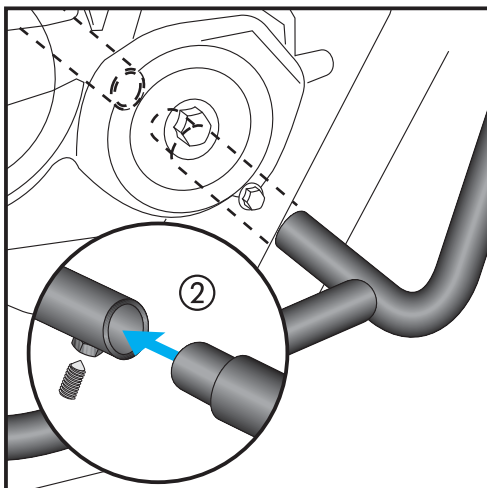

2

### Verbindung vorne:

- ① Die Mutter der hinteren Motoraufhängung lösen (siehe Bild 3). Motorschutzbügel auf das überstehende Gewinde schieben.
- ② Der Schutzbügel verläuft quer vor dem Motor durch und beide Seiten des Motorschutzbügels werden dort zusammengesteckt und mit der Stiftschraube M6 gesichert.

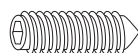

1x

## Motorschutzbügel

HONDA CBF 600 ab 2008  
Art.Nr.:501.953 00 01 schwarz

Seitenkoffer  
Topcases  
Gepäckträger  
Lock it System  
Softbags  
Aluminiumkoffer  
Lederkoffer  
Schutzbügel  
Hauptständer  
Chopper-Parts  
Quad-Parts  
Accessoires



## Montage

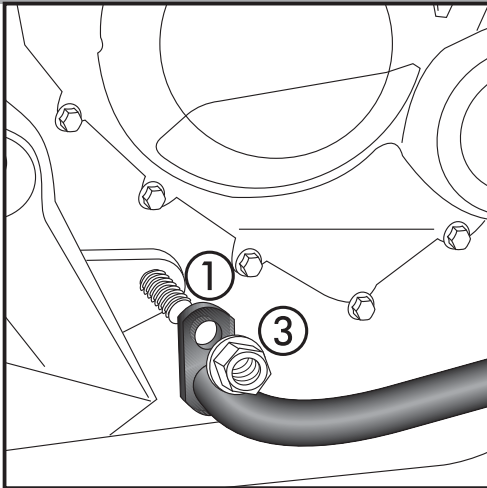

3

Befestigung rechts hinten:

③ Motorschutzbügel nun mit der Originalmutter befestigen.

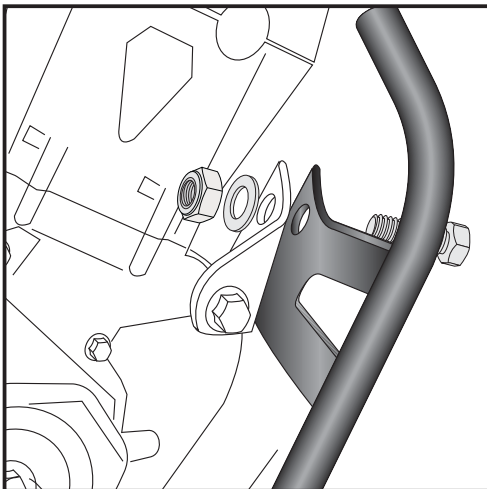

4

Befestigung rechts oben:

An der freien Bohrung der vorderen Motoraufhängung mit den Sechskantschrauben M 10 x 25 sowie U-Scheiben  $\varnothing 10,5$  und selbstsichernder Mutter M10.



**Nach der Montage alle Verschraubungen auf festen Sitz kontrollieren!**

**Bitte beachten Sie unsere beigefügten Serviceinformationen.**

Als weiteres Zubehör lieferbar:

650.953 01 01	Gepäckbrücke	CBF 600
650.953 00 01	Kofferträger	CBF 600 Lock it System (abnehmbar)
505.953 00 01	Hauptständer	CBF 600

503.938 00 01	Frontschutzbügel - speziell für Fahrschulen (für Model ohne Verkleidung)
504.953 00 01	Heckschutzbügel - speziell für Fahrschulen



**Hepco & Becker GmbH**  
Birkenstraße  
D-66989 Höffroschen

**Tel. 0049 (0) 6334 - 9216-0**  
**Fax 0049 (0) 6334 - 9216-80**  
**www.hepco-becker.de**

## Engine guard

**HONDA CBF 600**

from date of manufacture 2008

Item - No.: 501.953 00 01 black

Side cases

Top cases

Luggage frames

Lock it system

Softbags

Aluminium luggage

Leather luggage

Protection bars

Center stands

Chopper parts

Quad parts

Accessories



**HEPCO &  
BECKER**

## Assembling instructions

The kit includes the following parts:

Quant item no. description

1	701.515HB	crash bar left
1	701.516HB	crash bar right
2	150.850	Hexagon bolt M 10 x 25
4	150.811	washer $\varnothing$ 10,5 mm
2	150.801	self-lock nut M 10
1	151.059	Grub screw M6 x 10

## right side

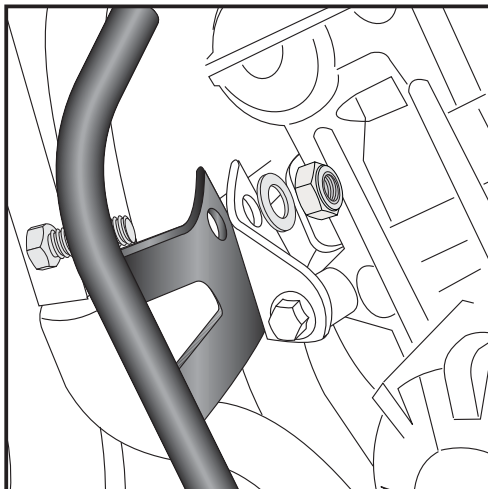
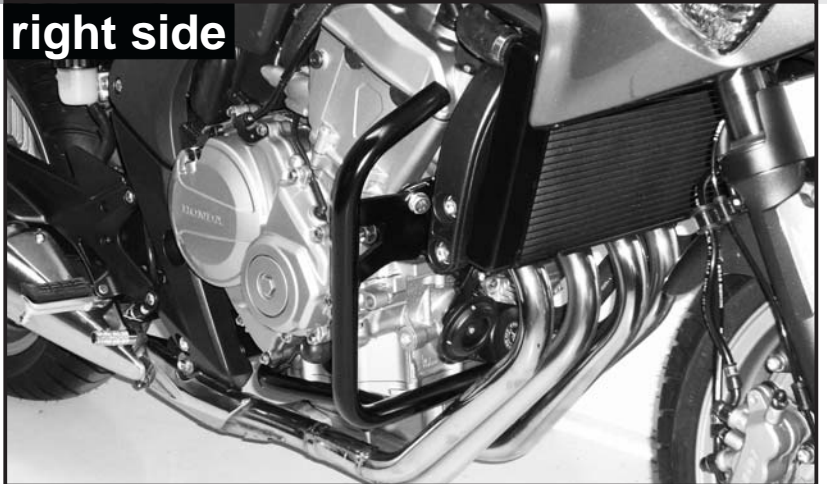

**1**

### Fastening of crash bar left top:

At the free boring of the engine bracket . Use hexagon bolt M 10 x 25 with washers  $\varnothing$ 10,5 and self-lock nut M10.

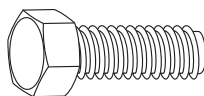

1x

2x



1x

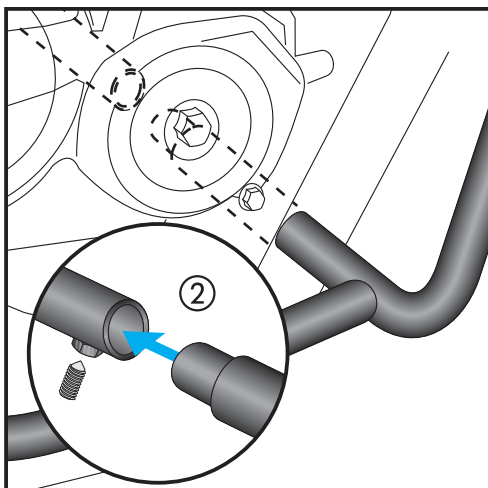
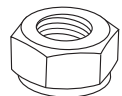

**2**

### Connection front:

① First unmount nut at the engine suspension (refer to picture 3). Put crash bar on the engine screw.

② In front of the engine, both parts of the engine guard will be connected. Fix it with the grub screw M6.



1x

Luggage ideas.

## Engine guard

**HONDA CBF 600**

from date of manufacture 2008

Item - No.: 501.953 00 01 black

Side cases

Top cases

Luggage frames

Lock it system

Softbags

Aluminium luggage

Leather luggage

Protection bars

Center stands

Chopper parts

Quad parts

Accessories



## Assembling instructions

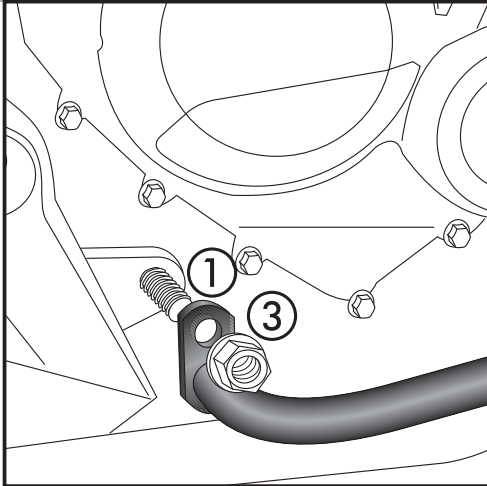

**3**

Fastening of crash bar right back:

③ Now fix the crash bar with original nut.

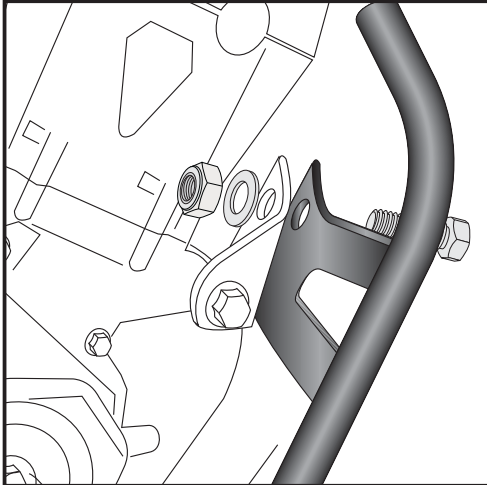

**4**

Fastening of crash bar right top:

At the free boring of the engine bracket . Use hexagon bolt M 10 x 25 with washers  $\varnothing 10,5$  and self-lock nut M10.



**Control all screw connections after the assembling for tightness!**

**Please notice our enclosed service information.**

**All screws, bolts and nuts should be checked after driving the first 50 km to ensure that all are tightened to the proper torque.**

Also available:

Side carrier 650.953 00 01 black, "Lock it System" (removable)

Rear rack 650.953 01 01 black

Centre stand 505.953 00 01 black

Front protection bar 503.938 00 01 - especially for driving schools (for Model without fairing)

Rear protection bar 504.953 00 01 - especially for driving schools



**Hepco & Becker GmbH**

**Birkenstraße**

**D-66989 H6hfr6schen**

**Tel. 0049 (0) 6334 - 9216-0**

**Fax 0049 (0) 6334 - 9216-80**

**www.hepco-becker.de**