

**THIS SHEET INCLUDES FITTING INSTRUCTIONS FOR THE FOLLOWING PARTS:**

Secondary Alternator Cover Part No. EC-MT10-2015-1-GBR / Secondary Clutch Cover Part No. EC-MT10-2015-2-GBR /  
 Secondary Pulse Cover Part No. EC-MT10-2015-3-GBR  
 Bullet Frame Race Slider Set - STREET - Part No. FS-R1-2015-S / Yamaha 6mm Paddock Stand / Bobbin Set Part No. BA12-6-GBR-SET /  
 Lower Chain Guard Part No. CGA10-GBR



**SECONDARY ALTERNATOR COVER**  
**PART NO. EC-MT10-2015-1-GBR**

1. Remove 4 existing bolts from the stock Alternator cover, shown as position Bolt 1, 2, 3 & 4.
2. Place the Secondary Alternator Cover over the stock cover.
3. Assemble 4 replacement bolts loosely in the correct position as shown.
4. Tighten bolts to a Torque of 12Nm as per Manufacturer's recommendations. **DO NOT OVERTIGHTEN.**

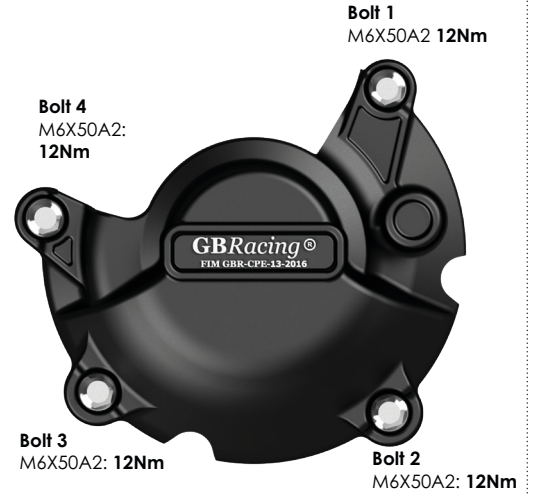
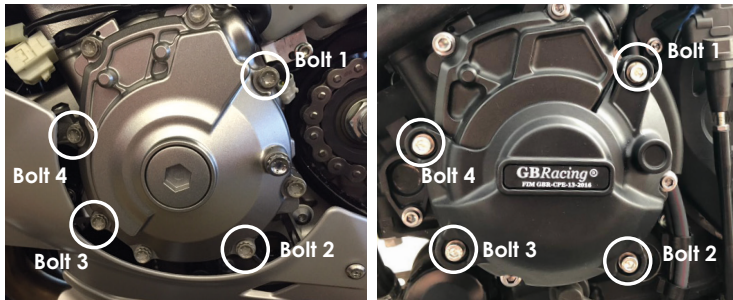

**SECONDARY CLUTCH COVER**  
**PART NO. EC-MT10-2015-2-GBR**

1. Remove 4 existing bolts from the stock Clutch cover, shown as position Bolt 1, 2, 3 & 4.
2. Place the Secondary Clutch Cover over the stock cover.
3. Assemble 4 replacement bolts loosely in the correct positions as shown.
4. Tighten bolts to a Torque of 12Nm as per Manufacturer's recommendations. **DO NOT OVERTIGHTEN.**

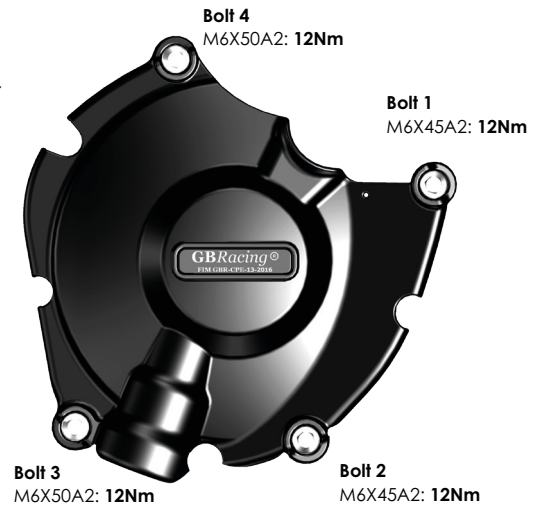
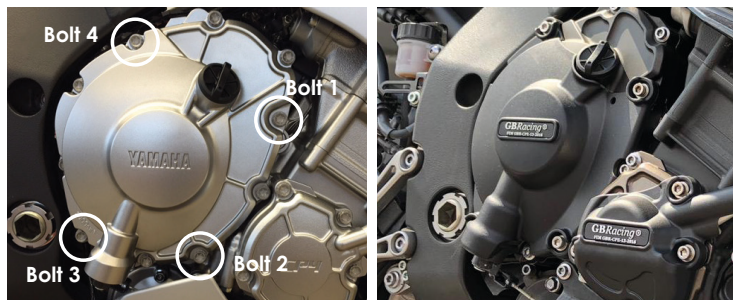

**SECONDARY PULSE COVER**  
**PART NO. EC-MT10-2015-3-GBR**

1. Remove 3 existing bolts from the stock pulse cover, shown as position Bolt 1, 2 & 3.
2. Place the Secondary Pulse Cover over the stock cover.
3. Assemble 3 replacement bolts loosely in the correct positions as shown.
4. Tighten bolts to a Torque of 12Nm as per Manufacturer's recommendations. **DO NOT OVERTIGHTEN.**

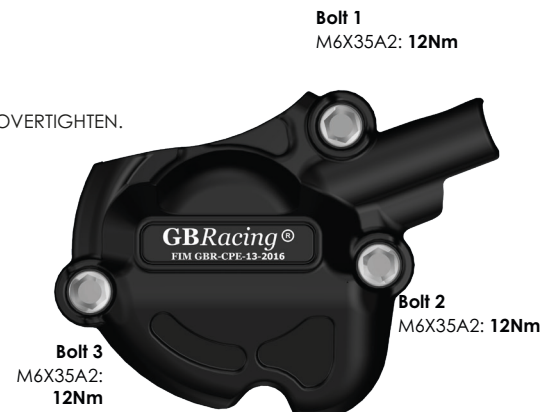
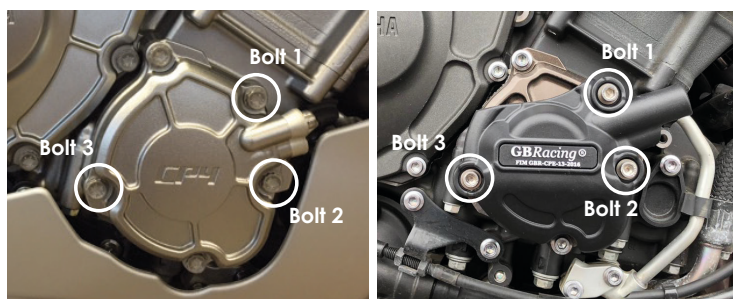

**BULLET FRAME SLIDER - LEFT HAND SIDE - STREET**  
**PART NO. FS-R1-2015-LHS-S**

- 1 Remove upper engine mounting bolt, located through the fairing opening.
- 2 Assemble bolt through the aluminium bush into correct position.
- 3 Tighten to 70NM torque.
- 4 Slide bullet moulding onto aluminium bush.
- 5 Screw M6 bolt into front of bullet moulding hand tight.



**BULLET FRAME SLIDER - RIGHT HAND SIDE - STREET**  
**PART NO. FS-R1-2015-RHS-S**

- 1 Remove upper engine mounting bolt, located through the fairing opening (*ensuring that the OE Washer is not removed*).
- 2 Assemble bolt through the aluminium bush into correct position.
- 3 Tighten to 70NM torque.
- 4 Slide bullet moulding onto aluminium bush.
- 5 Screw M6 bolt into front of bullet moulding hand tight.



**PADDOCK STAND / BOBBIN SET**  
**PART NO. BA12-6-GBR-SET**

- 1 Assemble M6 x 40mm Bolt & M6 Washer through the moulded bobbin.
- 2 Tighten bolts to swing arm boss, 8 Nm.  
DO NOT OVERTIGHTEN

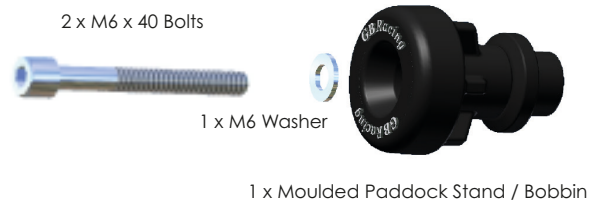

**LOWER CHAIN GUARD**  
**PART NO. CGA10-GBR**

- 1 Assemble 2 bolts and washers through the lower chain guard into the Black Anodised aluminium mounting block CGA10-2.
- 2 Position the assembly underneath the swing arm, closing the gap to the rear sprocket.  
Note : There should be a 5mm minimum gap from the bike chain to the lower chain guard.
- 3 Mark off the chosen hole positions.
- 4 Drill & Tap the marked holes , M6 - (Drill 5mm Dia. for tapping)
- 5 Disassemble the Black Anodised block from the assembly, and mount the block to the underside of the swing arm using the remaining 2 bolts and washers.
- 6 Re-assemble the lower chain guard to the fixed bracket.



[www.GBRacing.eu](http://www.GBRacing.eu)

**SET & BUNDLE:**

**Protection Bundle STREET: CP-MT10-2015-CS-GBR**

EC-MT10-2015-1-GBR, EC-MT10-2015-2-GBR, EC-MT10-2015-3-GBR, CGA10-GBR, FS-R1-2015-S, BA12-6-GBR-SET

**Engine Cover Set: EC-MT10-2015-SET-GBR**

EC-MT10-2015-1-GBR, EC-MT10-2015-2-GBR, EC-MT10-2015-3-GBR