

Motorschutzbügel

HONDA CTX 700 / N

Artikel-Nr.:
501.984 00 01 schwarz

Seitenkoffer
Topcases
Gepäckträger
Lock it System
Softbags
Aluminiumkoffer
Lederkoffer
Schutzbügel
Hauptständer
Chopper-Parts
Accessoires



Montage

Der Bausatz umfaßt die folgenden Teile:

Stück	Bestellnr.	Bezeichnung
1	700008520	Motorschutzbügel links
1	700008521	Motorschutzbügel rechts
1	700008522	Verbindungsbügel
2	150.938	Linienkopfschrauben M8x20
1	151.458	Inbusschraube M12x70x1,25
1	151.459	Inbusschraube M12x50x1,25
4	150.810	U-Scheibe Ø8,4
2	151.010	U-Scheibe Ø12,4
2	150.800	Selbstsichernde Mutter M8
2	275.001	Anschlaggummi

Achtung !

Bei der Montage der Motorschutzbügel immer nur eine Seite nach der anderen montieren - dies verhindert ein Absenken des Motors.

Tipp:

Schrauben sie alle Teile an und lassen sie die zugänglichen Schrauben etwas locker. Nachdem alles montiert ist, werden alle Schrauben auf das entsprechende Anzugsmoment angezogen. Dadurch wird sicher-gestellt, dass das Produkt spannungsfrei angebaut ist. Damit ist eine lange Lebensdauer sichergestellt !



Anzugsmomente des Motorradherstellers beachten!
Nach der Montage alle Verschraubungen auf festen Sitz kontrollieren!
Bitte beachten Sie unsere beigefügten Serviceinformationen.

Als weiteres Zubehör lieferbar:

Kofferträger Lock it (abnehmbar)	Art.-Nr.: 650.984 00 01
Gepäckbrücke Alurack	Art.-Nr.: 650.984 01 01
C-Bow Halter für Softtaschen	Art.-Nr.: 630.984



Hepco & Becker GmbH
An der Steinmauer 6
D-66955 Pirmasens

Tel.: 06331 - 1453 - 100
Fax: 06331 - 1453 - 120
eMail: vertrieb@hepco-becker.de
www.hepco-becker.de

Motorschutzbügel

HONDA CTX 700 / N

Artikel-Nr.:
501.984 00 01 schwarz

- Seitenkoffer
- Topcases
- Gepäckträger
- Lock it System
- Softbags
- Aluminiumkoffer
- Lederkoffer
- Schutzbügel
- Hauptständer
- Chopper-Parts
- Accessoires



Montage

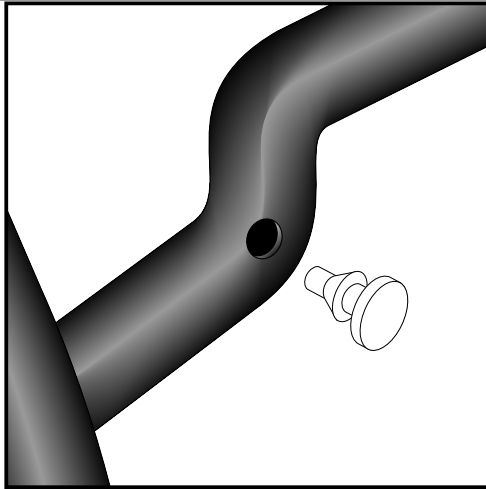

1

Vorbereitung:

Bugspoiler-Vorderteil demontieren.
In die freie Bohrung auf der Rückseite der Sturzbügel die Anschlaggummis eindrehen (eventuell etwas Fett benutzen).

2x

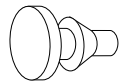

Montage des Motorschutzbügels vorne rechts:

an den beiden vorderen Schrauben der Rahmenverschraubung mit den Originalschrauben.

2

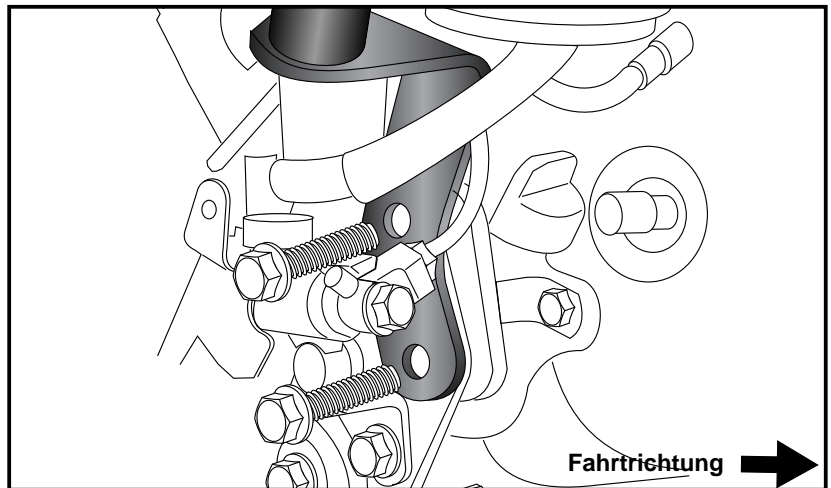

Fahrtrichtung →

Montage des Motorschutzbügels hinten rechts:

an der mittleren Motoraufhängung. Originalschraube entfällt.
Zur Befestigung die Inbusschraube M12x70x1,25 sowie die U-Scheibe Ø12,4 verwenden.
Achtung ! Auf die Zwischendistanz achten, daß diese wieder zwischen Halter und Motor sitzt.

3

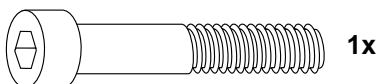
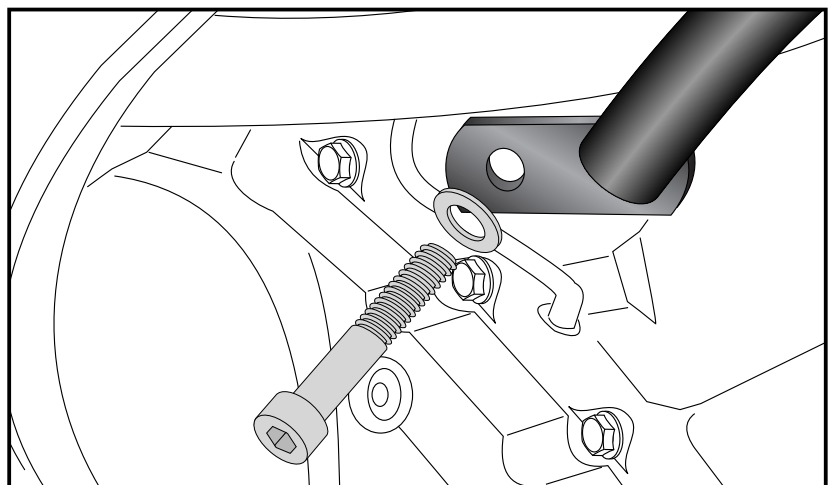

1x



1x

Motorschutzbügel

HONDA CTX 700 / N

Artikel-Nr.:
501.984 00 01 schwarz

Seitenkoffer
Topcases
Gepäckträger
Lock it System
Softbags
Aluminiumkoffer
Lederkoffer
Schutzbügel
Hauptständer
Chopper-Parts
Accessoires



Montage

Montage des Motorschutzbügels vorne links:

an den beiden vorderen Schrauben der
Rahmenverschraubung mit den
Originalschrauben.

4

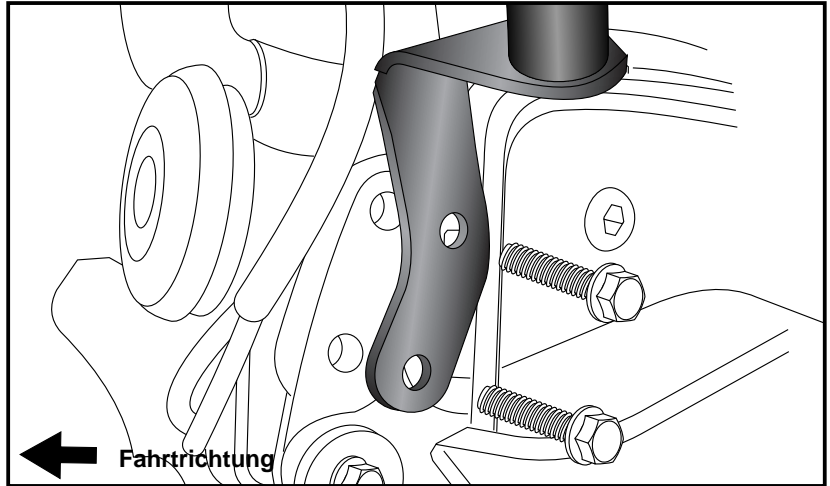

Montage des Motorschutzbügels vorne rechts:

an der mittleren Motoraufhängung
Originalschraube entfällt.
Zur Befestigung die Inbusschraube
M12x50x1,25 sowie U-Scheibe Ø12,4
verwenden.

5

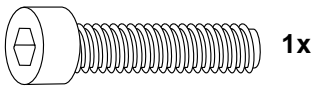
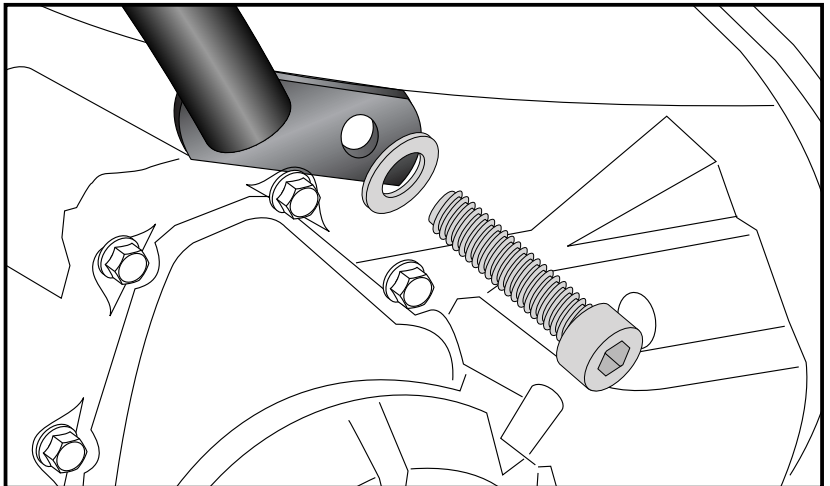

Montage des Verbindungsbügels vorne links und rechts:

er verläuft unterhalb des Kühlers quer
zum Sturzbügel.
Die Verschraubung erfolgt an den kleinen
Laschen am Sturzbügel mit den
Linsenkopfschrauben M8x20 sowie U-
Scheiben ø 8,4 und selbstsichernder
Mutter M8.
Bugspoiler Vorderteil wieder montieren.

5

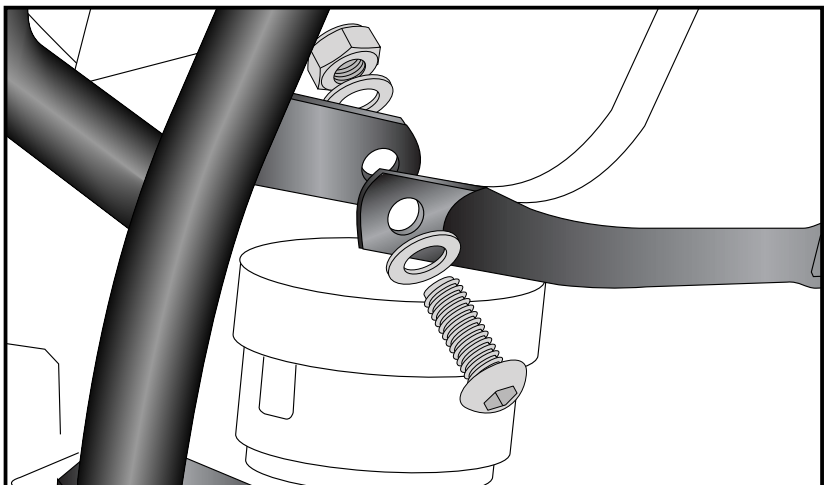

Engine guard

HONDA CTX 700 / N

Item-No.:
501.984 00 01 black

Side cases
Top cases
luggage frames
Lock it system
Softbags
Aluminium luggage
Leather luggage
Protection bars
Center stands
Chopper parts
Accessories



Assembling instructions

The kit includes the following parts:

Quant	item no.	description
1	700008520	crash bar left
1	700008521	crash bar right
1	700008522	bracing bow
2	150.938	filister head screw M8x20
1	151.458	allen screw M12x70x1,25
1	151.459	allen screw M12x50x1,25
4	150.810	washer Ø8,4
2	151.010	washer Ø12,4
2	150.800	self lock nut M8
2	275.001	rubber stop

Attention!

When assembling the engine guard, do it one side after the other - this will prevent a lowering of the engine block.

Tip:

Fit all parts and screw on not too strong.
After mounting all parts, the screws should be tightened to the torque specified.
This guarantees, that the kit is mounted without tension.

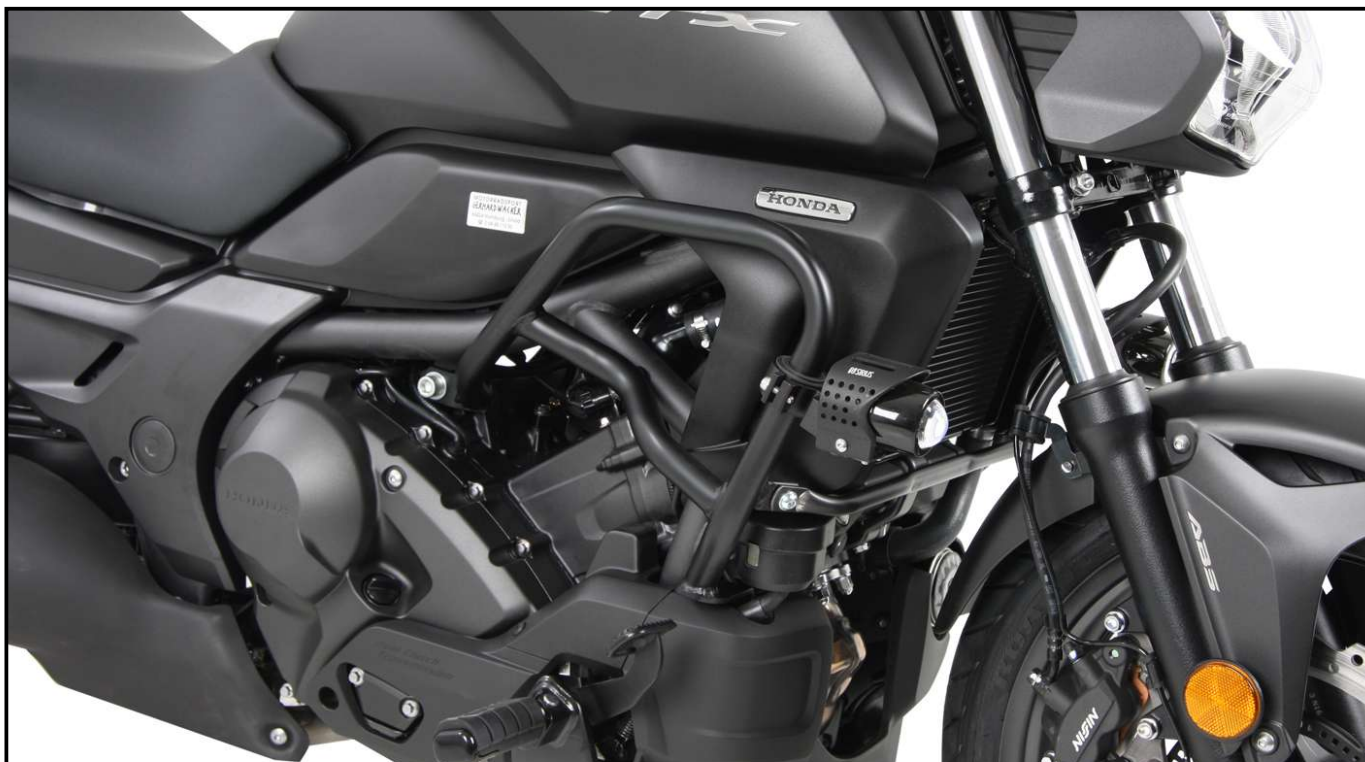

Control all screw connections after the assembling for tightness!
Please notice our enclosed service information.

Also available:

Side carrier (Lock it, can be removed)

Rear rack (Alurack)

C-Bow Holder for softbags

Item-No. 650.3526 00 01

Item-No. 650.3526 01 01

Item-No. 630.3526



Hepco & Becker GmbH
An der Steinmauer 6
D-66955 Pirmasens
Germany

Tel.: +49 6331 - 1453 - 100

Fax: +49 6331 - 1453 - 120

eMail: vertrieb@hepco-becker.de

www.hepco-becker.de

Engine guard

HONDA CTX 700 / N

Item-No.:
501.984 00 01 black

- Side cases
- Top cases
- luggage frames
- Lock it system
- Softbags
- Aluminium luggage
- Leather luggage
- Protection bars
- Center stands
- Chopper parts
- Accessories



Assembling instructions

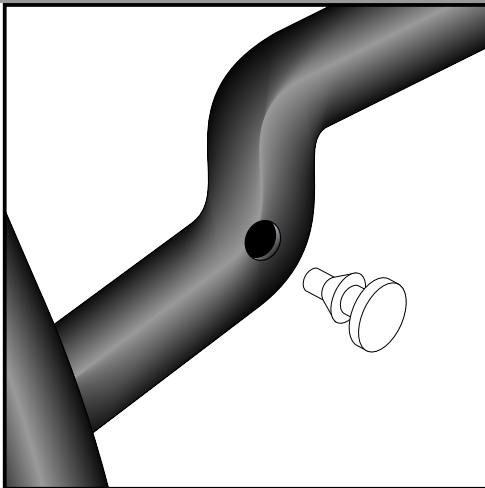

1

Preparing:

Dismantle the front part of the spoiler.

Stick the rubber stopper in the free borings on the back of the crash bars (possibly use some grease).

2x

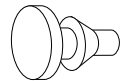

Fastening of the crash bar front right:

at both front boltings of the frame with original screws.

2

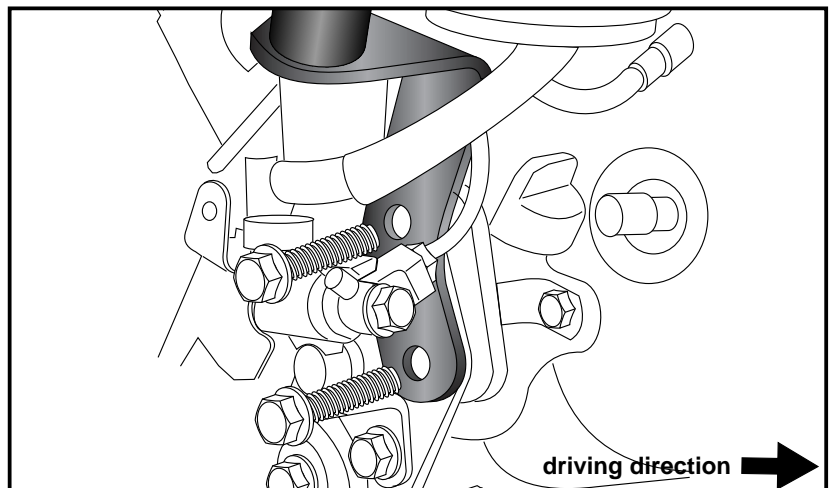

driving direction →

Fastening of the crash bar rear right:

at the center engine mount.
Original screw is obsolete.
Use allen screws M12x70x1,25 with washer Ø12,4.

Attention! Ensure that the original spacer is added between holder and engine block.

3

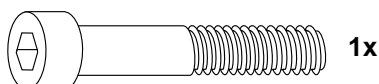
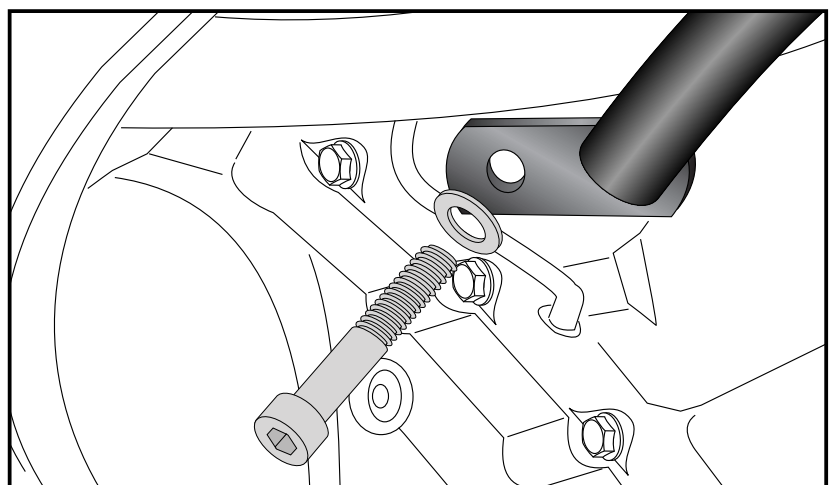

1x



1x

Engine guard

HONDA CTX 700 / N

Item-No.:
501.984 00 01 black

- Side cases
- Top cases
- luggage frames
- Lock it system
- Softbags
- Aluminium luggage
- Leather luggage
- Protection bars
- Center stands
- Chopper parts
- Accessories



Assembling instructions

Fastening of the crash bar front left:

at both front boltings of the frame with
original screws.

4

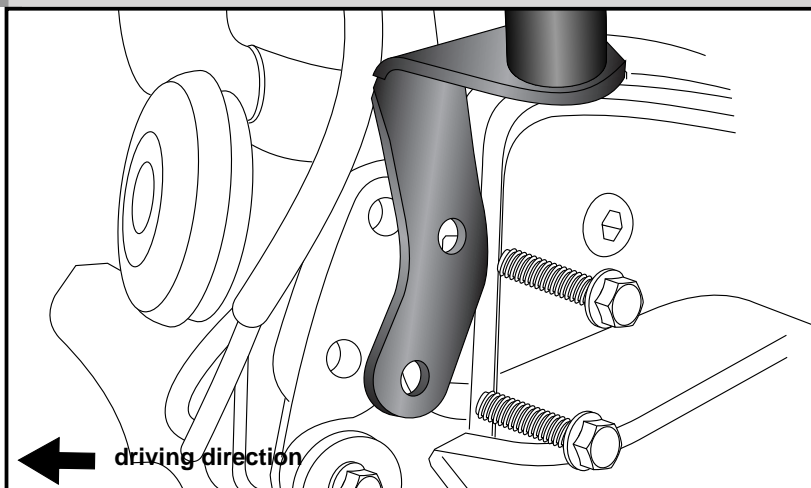

Fastening of the crash bar rear left:

at the center engine mount.
Original screw is obsolete.
Use allen screws M12x70x1,25 with
washer Ø12,4.

5

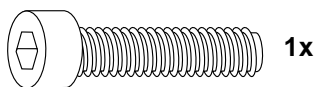
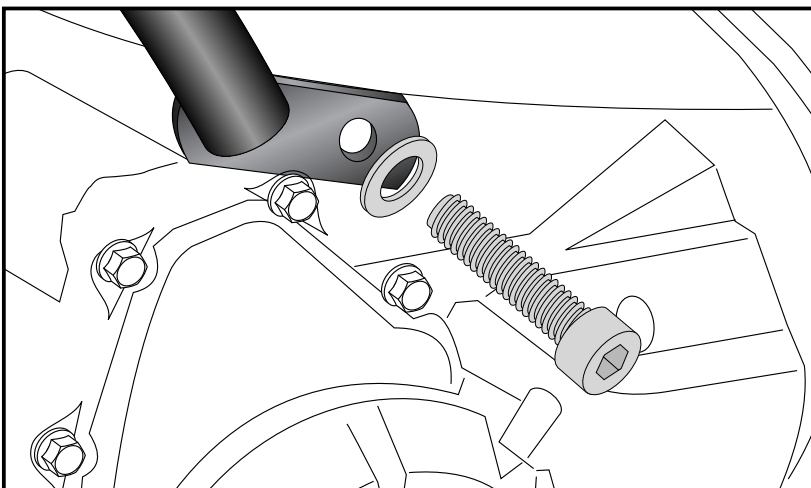

Fastening of the bracing bow front left + right:

it runs in front of the cooler.
Screwing on the small tabs on the crash
bars with filister head screws M8 x 20 with
washers ø8,4 and self lock nuts M8.

Mount spoiler again.

5

