

## Motorschutzbügel

BMW F 800 R

Art.-Nr.:  
502.937 00 01 schwarz

Seitenkoffer  
Topcases  
Gepäckträger  
Lock it System  
Softbags  
Aluminiumkoffer  
Lederkoffer  
Schutzbügel  
Hauptständer  
Chopper-Parts  
Quad-Parts  
Accessoires



## Montage

Der Bausatz umfaßt die folgenden Teile:

Stück	Bestellnr.	Bezeichnung
1	705.526HB	Motorschutzbügel links
1	705.527HB	Motorschutzbügel rechts
1	151.080	Inbusschraube M 10 x 120
1	151.253	Inbusschraube M 10 x 110
2	150.877	Inbusschraube M 10 x 90
4	150.811	U-Scheibe ø10,4
1	151.252	Stahldistanz ø18 x ø13 x 58mm
1	151.251	Stahldistanz ø18 x ø13 x 48mm



**Achtung: Sturzbügelhälften immer nur wechselseitig montieren da die Gefahr der Motorabsenkung besteht.**

**Anzugsmomente des Motorradherstellers beachten!  
Nach der Montage alle Verschraubungen auf festen Sitz kontrollieren!  
Bitte beachten Sie unsere beigefügten Serviceinformationen.**

Als weiteres Zubehör lieferbar:

Gepäckbrücke (Aluminium Rack)

Art.-Nr.: 650.657 01 01

Lampenschutzgitter

Art.-Nr.: 700.657 00 01



**Hepco & Becker GmbH**  
An der Steinmauer 6

D-66955 Pirmasens

Tel.: 06331 - 1453 - 100

Fax: 06331 - 1453 - 120

eMail: [vertrieb@hepco-becker.de](mailto:vertrieb@hepco-becker.de)

[www.hepco-becker.de](http://www.hepco-becker.de)

# Motorschutzbügel

BMW F 800 R

Art.-Nr.:  
502.937 00 01 schwarz

- Seitenkoffer
- Topcases
- Gepäckträger
- Lock it System
- Softbags
- Aluminiumkoffer
- Lederkoffer
- Schutzbügel
- Hauptständer
- Chopper-Parts
- Quad-Parts
- Accessoires



## Montage

**Montage des Motorschutzbügels links:**  
An den oberen zwei Punkten der Motoraufhängung.  
Originalschrauben entfallen.  
Vorne: **1**  
Die Stahldistanz  $\varnothing 18 \times \varnothing 13 \times 58$  mm einfügen, mit Inbusschraube M 10x120 und U-Scheibe  $\varnothing 10,4$  verschrauben.  
Hinten: **2**  
mit Inbusschraube M 10 x 90 und U-Scheibe  $\varnothing 10,4$  verschrauben.

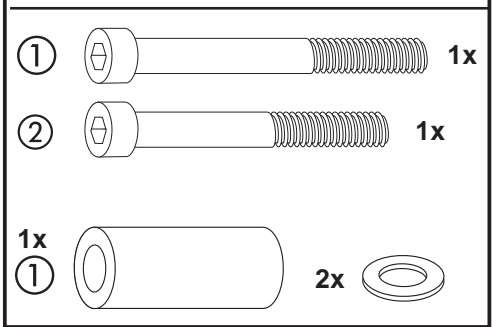

### 1 Linke Seite

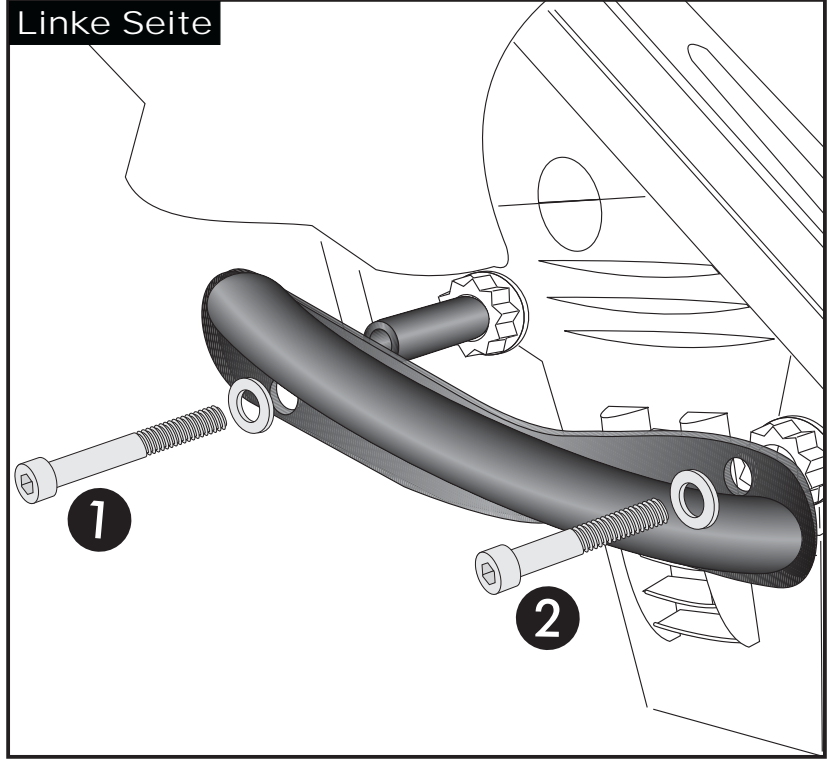

**Montage des Motorschutzbügels rechts:**  
An den oberen zwei Punkten der Motoraufhängung.  
Originalschrauben entfallen.  
Vorne: **3**  
Die Stahldistanz  $\varnothing 18 \times \varnothing 13 \times 48$  mm einfügen, mit Inbusschraube M 10 x 110 und U-Scheibe  $\varnothing 10,4$  verschrauben.  
Hinten: **4**  
mit Inbusschraube M 10 x 90 und U-Scheibe  $\varnothing 10,4$  verschrauben.

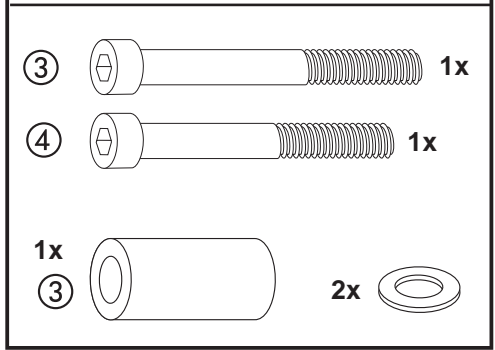

### 2 Rechte Seite

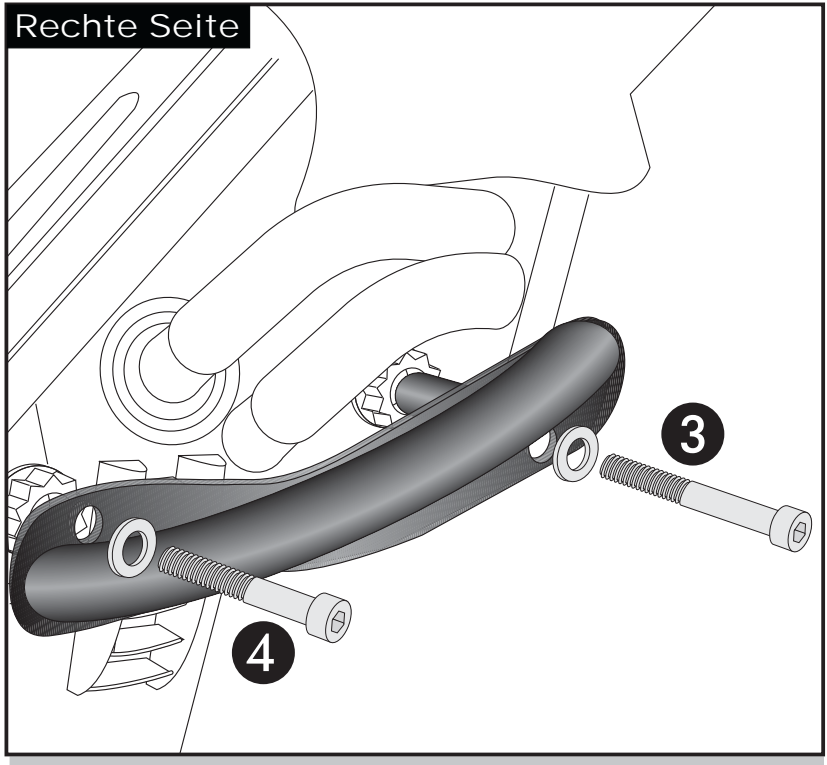

Engine guard

BMW F 800 R

Art.-Nr.:  
502.937 00 01 black

Side cases

Top cases

luggage frames

Lock it system

Softbags

Aluminium luggage

Leather luggage

Protection bars

Center stands

Chopper parts

Quad parts

Accessories



## Assembling instructions

The kit includes the following parts:

Quant	item no.	description
1	705.526HB	Engine guard, left
1	705.527HB	Engine guard, right
1	151.080	allen screw M 10 x 120
1	151.253	allen screw M 10 x 110
2	150.877	allen screw M 10 x 90
4	150.811	washer $\varnothing 10,4$
1	151.252	steel spacer $\varnothing 18 \times \varnothing 13 \times 58\text{mm}$
1	151.251	steel spacer $\varnothing 18 \times \varnothing 13 \times 48\text{mm}$

### WARNING:

Do it side by side, starting with the left side. Otherwise the engine block can move down.



Control all screw connections after the assembling for tightness!  
Please notice our enclosed service information.

Also available:  
Rear aluminium rack  
Headlight grille

Item.-No.: 650.657 01 01  
Item.-No.: 700.657 00 01



Hepco & Becker GmbH  
An der Steinmauer 6  
D-66955 Pirmasens  
Germany

Tel.: +49 6331 - 1453 - 100  
Fax: +49 6331 - 1453 - 120  
eMail: [vertrieb@hepco-becker.de](mailto:vertrieb@hepco-becker.de)  
[www.hepco-becker.de](http://www.hepco-becker.de)

# Engine guard

BMW F 800 R

Art.-Nr.:  
502.937 00 01 black

Side cases

Top cases

luggage frames

Lock it system

Softbags

Aluminium luggage

Leather luggage

Protection bars

Center stands

Chopper parts

Quad parts

Accessories



**HEPCO &  
BECKER**

## Assembling instructions

Fastening of the engine guard left:  
at the two upper points of the engine  
suspension. Original screws are obsolete.

Front: **1**  
sandwich steel spacer  $\varnothing 25 \times \varnothing 11 \times 58$   
and fix it with allen screw M 10 x 120  
and washer  $\varnothing 10,4$ .

Rear: **2**  
fix it with allen screw M 10 x 90  
and washer  $\varnothing 10,4$ .

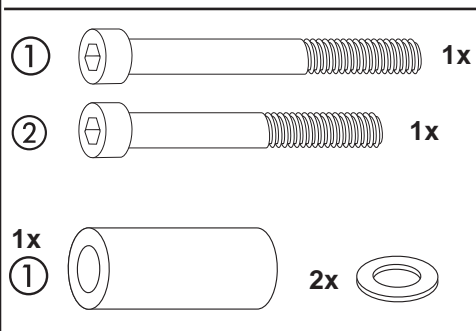

### 1 left side

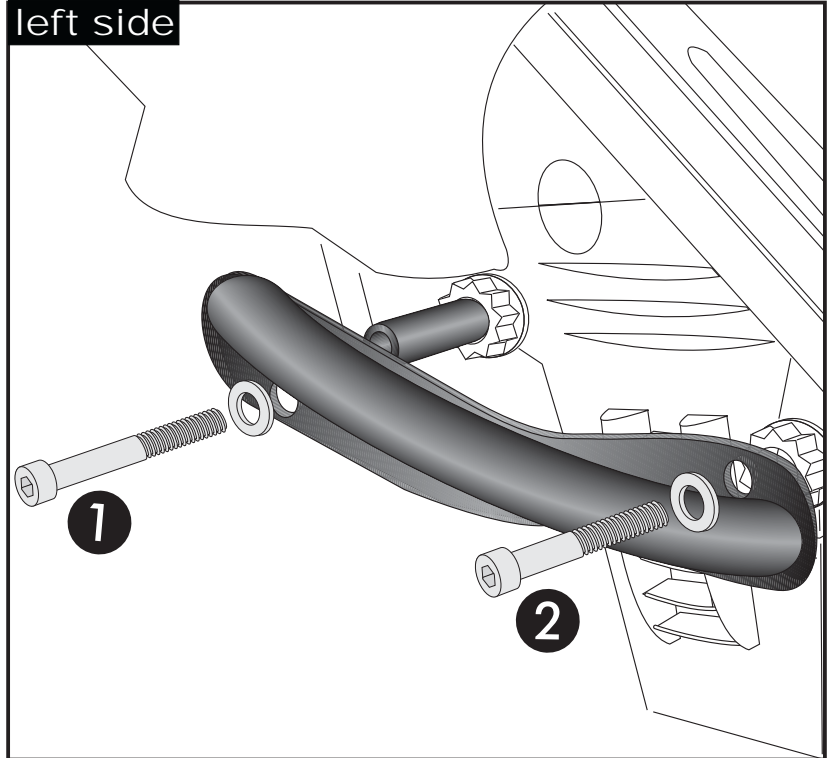

Fastening of the engine guard right:  
at the two upper points of the engine  
suspension. Original screws are obsolete.

Front: **3**  
sandwich steel spacer  $\varnothing 25 \times \varnothing 11 \times 48$   
and fix it with allen screw M 10 x 110  
and washer  $\varnothing 10,4$ .

Rear: **4**  
fix it with allen screw M 10 x 90  
and washer  $\varnothing 10,4$ .

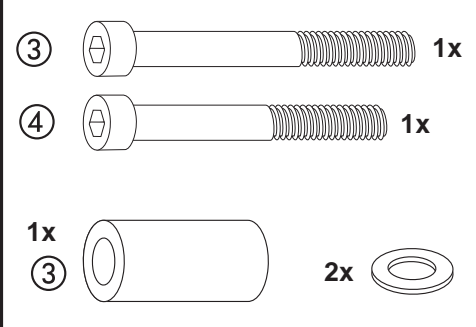

### 2 right side

