

**Heckschutzbügel
Lock it System (abnehmbar)**

HONDA NC 700 X
Artikel-Nr.: 504.973 00 01 schwarz

HONDA NC 700 S
Artikel-Nr.: 504.970 00 01 schwarz



Montage

Der Bausatz umfaßt die folgenden Teile:

St.	Bestellnr.	Bezeichnung
1	700007779	Heckschutzbügel links
1	700007780	Heckschutzbügel rechts
1	700007781	Halteadapter oben links
1	700007782	Halteadapter oben rechts
1	700007783	Halteadapter unten links
1	700007784	Halteadapter unten rechts
4	150.784	Inbusschraube M8x30
2	150.838	Sechskantschraube M8x16
2	150.840	Sechskantschraube M8x25
8	150.810	U-Scheiben Ø8,4
4	150.808	Karoseriescheiben Ø26xØ8,4x1,5mm
2	150.882	Aludistanz Ø18xØ9x10mm
4	270.100	Stopfen f. Bohrungen Ø12
6	151.070	Lock-it Systemschrauben
6	151.071	Sicherungsscheiben Lock it

Soziusbetrieb ist nach Montage des Heckschutzbügels nicht eingeschränkt.

HINWEIS:

Das es sich um die gleichen Adapter handelt wie beim Kofferträger, können die Kofferträger auch anstelle der Schutzbügel montiert werden. Desweiteren kann zusätzlich das Alurack montiert werden.

- Seitenkoffer
- Topcases
- Gepäckträger
- Lock it System
- Softbags
- Aluminiumkoffer
- Lederkoffer
- Schutzbügel
- Hauptständer
- Chopper-Parts
- Quad-Parts
- Accessoires



Anzugsmomente des Motorradherstellers beachten!
Nach der Montage alle Verschraubungen auf festen Sitz kontrollieren!
Bitte beachten Sie unsere beigefügten Serviceinformationen.

Als weiteres Zubehör lieferbar:

- Alurack (kombinierbar)
- Lock it Seitenträger (anstelle Heckschutz)
- Motorschutzbügel
- C-Bow Halter für Softtaschen
- Hauptständer
- Frontschutzbügel für Fahrschulen

Honda NC 700 X

- Art.-Nr.: 650.973 01 01
- Art.-Nr.: 650.973 01 01
- Art.-Nr.: 501.973
- Art.-Nr.: 630.973
- Art.-Nr.: 505.973
- Art.-Nr.: 503.973

Honda NC 700 S

- Art.-Nr.: 650.970 01 01
- Art.-Nr.: 650.970 00 01
- Art.-Nr.: 501.970
- Art.-Nr.: 630.970
- Art.-Nr.: 505.970
- Art.-Nr.: 503.970



Hepco & Becker GmbH
An der Steinmauer 6

D-66955 Pirmasens

Tel.: 06331 - 1453 - 100

Fax: 06331 - 1453 - 120

eMail: vertrieb@hepco-becker.de

www.hepco-becker.de

160312/090512

Heckschutzbügel Lock it System (abnehmbar)

HONDA NC 700 X
Artikel-Nr.: 504.973 00 01 schwarz

HONDA NC 700 S
Artikel-Nr.: 504.970 00 01 schwarz



Montage

Seitenkoffer
Topcases
Gepäckträger
Lock it System
Softbags
Aluminiumkoffer
Lederkoffer
Schutzbügel
Hauptständer
Chopper-Parts
Accessoires



Vorbereitung:

Soziussitzbank öffnen, und die Haltegriffe demontieren. Blinker werden nicht versetzt.

Montage der Halteadapter links und rechts :

Den Halteadapter zusammen mit den Haltegriffen mit den Inbusschrauben M8x30 sowie U-Scheiben Ø8,4 montieren. Zwischen Adapter und Rahmen die Karosseriescheiben Ø26xØ8,4x1,5mm fügen.

Tipp:

Schrauben sie alle Teile an und lassen sie die zugänglichen Schrauben etwas locker. Nachdem alles montiert ist, werden alle Schrauben auf das entsprechende Anzugsmoment angezogen. Dadurch wird sichergestellt, dass das Produkt spannungsfrei angebaut ist. Damit ist eine lange Lebensdauer sichergestellt !

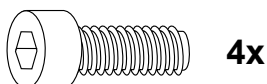

1

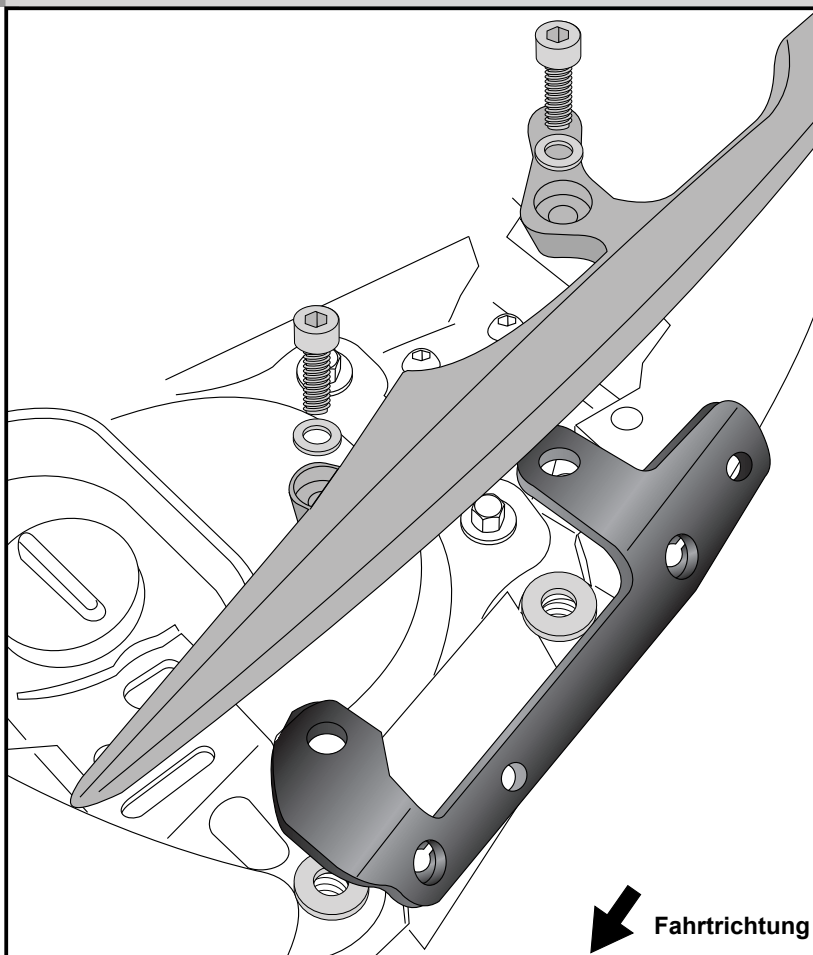

Befestigung der Halteadapter vorne unten links und rechts:

An den Gewindebohrungen auf der Rückseite der Soziusfußrastenauslegers. Vorne: ① mit der Sechskantschraube M8x16 sowie U-Scheibe Ø8,4. Hinten: ② mit der Sechskantschraube M8x25 sowie U-Scheibe Ø8,4. Aludistanz Ø18xØ9x10mm zwischen Ausleger und Adapter fügen.

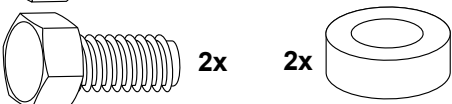
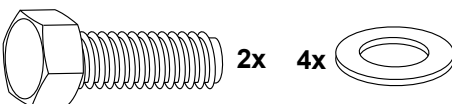

2

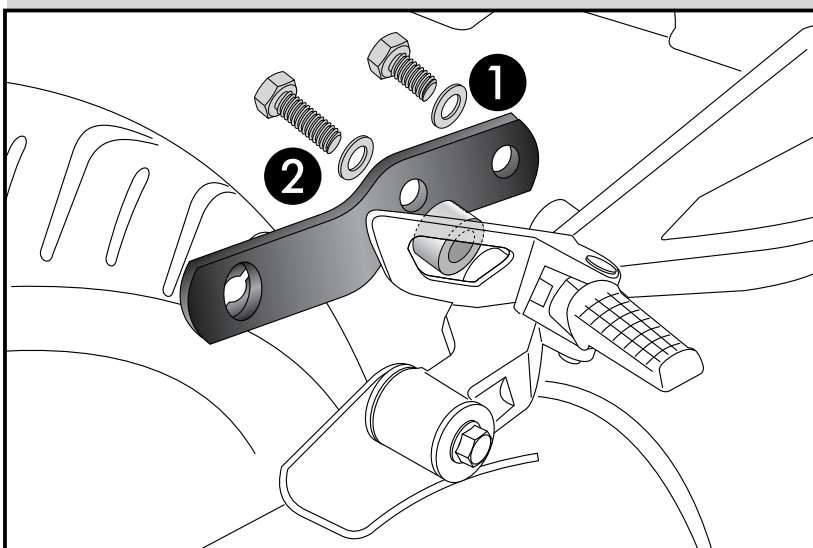

Heckschutzbügel
Lock it System (abnehmbar)

HONDA NC 700 X
Artikel-Nr.: 504.973 00 01 schwarz

HONDA NC 700 S
Artikel-Nr.: 504.970 00 01 schwarz



Montage

- Seitenkoffer
- Topcases
- Gepäckträger
- Lock it System
- Soffbags
- Aluminiumkoffer
- Lederkoffer
- Schutzbügel
- Hauptständer
- Chopper-Parts
- Accessoires

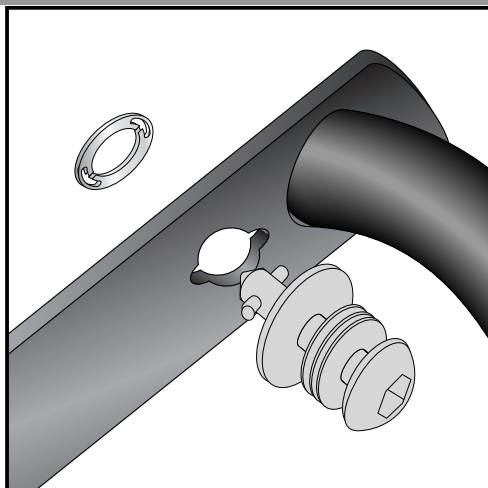

3 Montage der Lock it System-Schrauben:
An den Kofferträgern links / rechts werden die Lock it System-Schrauben an den Befestigungslaschen mittels der Sicherungsscheibe montiert. Die Scheiben und Lock it System-Schrauben verbleiben bei Demontage an den Befestigungspunkten der Kofferträger.

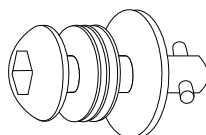

6x

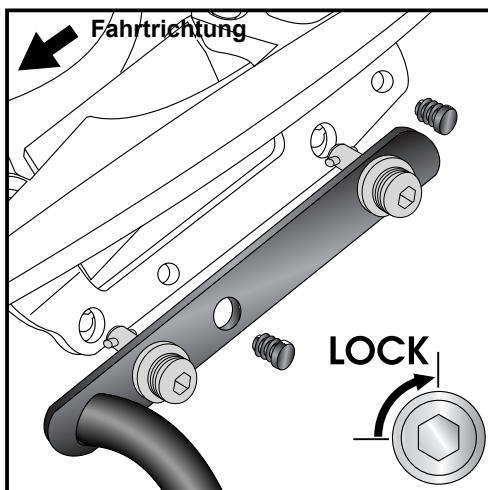

4 Montage der Heckschutzbügel links / rechts oben:
Die vorbereiteten Heckschutzbügel werden an den Halteadaptern mittels der Lock it System-Schrauben befestigt.

In die freien Bohrungen der Halteadapter die mitgelieferten Stopfen Ø12mm eindrücken. Die Bohrungen sind für die zusätzliche Montage eines Alu-Racks vorgesehen.

ACHTUNG:

Lock it System-Schrauben nicht überdrehen !
Langsam drehen (Viertelumdrehung) bis die Schraube fühlbar einrastet und am Anschlag anliegt.



4x

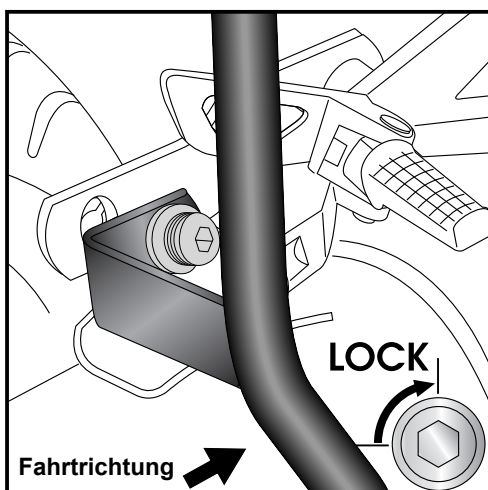

5 Montage der Heckschutzbügel links / rechts unten:
Die Heckschutzbügel werden an den Halteadaptern mittels der Lock it System-Schrauben befestigt.

ACHTUNG:

Lock it System-Schrauben nicht überdrehen !
Langsam drehen (Viertelumdrehung) bis die Schraube fühlbar einrastet und am Anschlag anliegt.

Rear protection bar
for driving schools
Lock it System (removable)

HONDA NC 700 X

Item - No.: 504.973 00 01 black

HONDA NC 700 S

Item - No.: 504.970 00 01 black



Side cases

Top cases

luggage frames

Lock it system

Softbags

Aluminium luggage

Leather luggage

Protection bars

Center stands

Chopper parts

Accessories



Assembling instructions

The kit includes the following parts:

Quant	item no.	description
1	700007779	Rear guard left
1	700007780	Rear guard right
1	700007781	rack adapter left
1	700007782	rack adapter right
1	700007783	adapter bottom left
1	700007784	adapter bottom right
4	150.784	allen screw M8x30
2	150.838	hexagon bolt M8x16
2	150.840	hexagon bolt M8x25
8	150.810	washer Ø8,4
4	150.808	body washer Ø26xØ8,4x1,5mm
2	150.882	alu spacer Ø18xØ9x10mm
4	270.100	plastic plug for boring Ø12
6	151.070	lock-it screw
6	151.071	lock washer

Pillion operation after installation of the rear crash bar is not restricted.

NOTICE:

Adapters are the same, than in the side carrier kit. Therefore it's possible to mount a side carrier instead of the rear guard. Mounting an alurack is also possible.



Control all screw connections after the assembling for tightness!
Please notice our enclosed service information.

Also available:

	Honda NC 700 X	Honda NC 700 S
Alurack (can be combined)	Item-No. 650.973 01 01	Item-No. 650.970 01 01
Lock it side carrier (instead of the protection bar)	Item-No. 650.973 01 01	Item-No. 650.970 00 01
Engine guard	Item-No. 501.973	Item-No. 501.970
C-Bow Holder for softbags	Item-No. 630.973	Item-No. 630.970
Center stand	Item-No. 505.973	Item-No. 505.970
Front protection bar for driving schools	Item-No. 503.973	Item-No. 503.970



Hepco & Becker GmbH
An der Steinmauer 6
D-66955 Pirmasens
Germany

Tel.: +49 6331 - 1453 - 100
Fax: +49 6331 - 1453 - 120
eMail: vertrieb@hepco-becker.de
www.hepco-becker.de

Rear protection bar
for driving schools
Lock it System (removable)

HONDA NC 700 X

Item - No.: 504.973 00 01 black

HONDA NC 700 S

Item - No.: 504.970 00 01 black



Side cases

Top cases

luggage frames

Lock it system

Softbags

Aluminium luggage

Leather luggage

Protection bars

Center stands

Chopper parts

Accessories



Assembling instructions

Preparing:

Open seat and dismantle handle bars.
Blinker remains in their original position.

Fastening of the rack adapter left and right :

together with the handle bars with allen screws M8 x 30 and washer Ø8,4.
Sandwich body washers
Ø26xØ8,4x1,5mm between adapter and
frame.

Tip:

Fit all parts and screw on not too strong.
After mounting all parts, the screws
should be tightened
to the torque specified.
This guarantees, that the kit is mounted
without tension.

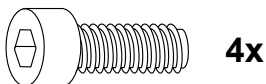

4x



4x

4x

1

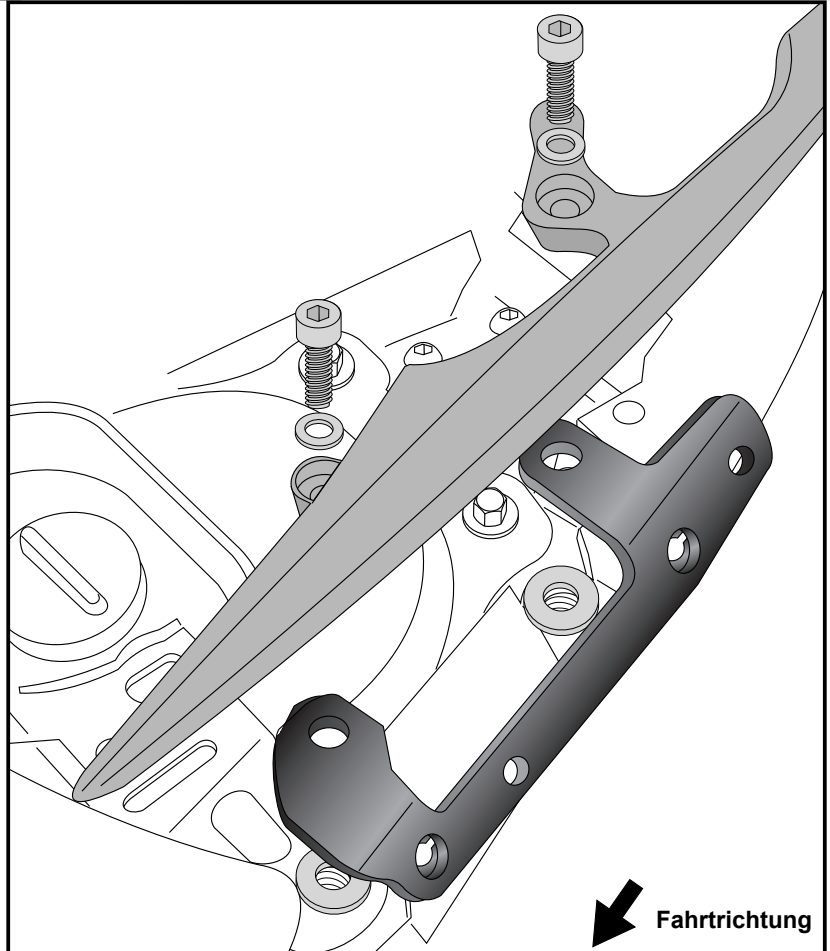

Fastening of the adapter bottom left and right:

at the free threads behind the footrest
bracket.

Front: ① use hexagon bolt M8 x 16 and
washer Ø8,4.

Rear: ② use hexagon bolt M8 x 25 and
washer Ø8,4. Sandwich alu spacer
Ø18xØ9x10mm between bracket and
adapter.

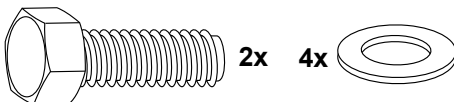

2x

4x

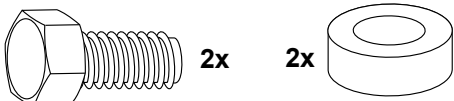

2x

2x



2

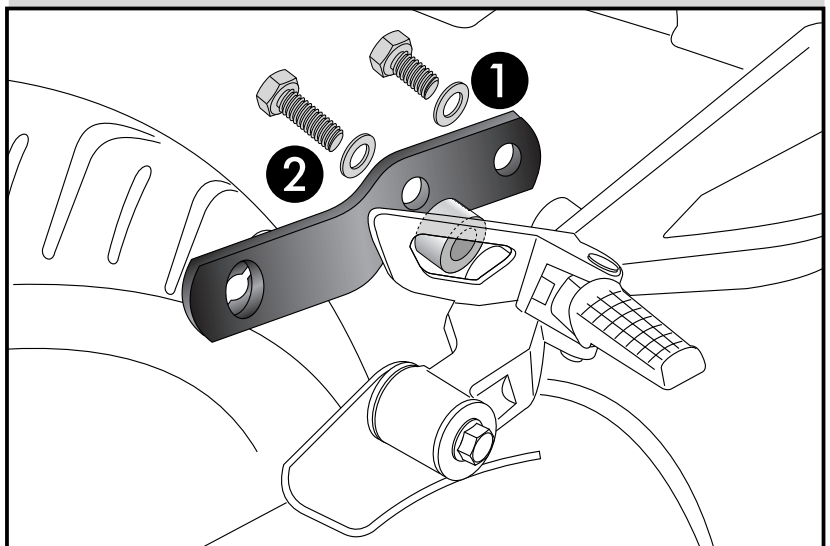

Luggage ideas.

2

Rear protection bar
for driving schools
Lock it System (removable)

HONDA NC 700 X
Item - No.: 504.973 00 01 black
HONDA NC 700 S
Item - No.: 504.970 00 01 black



- Side cases
- Top cases
- luggage frames
- Lock it system
- Softbags
- Aluminium luggage
- Leather luggage
- Protection bars
- Center stands
- Chopper parts
- Accessories



Assembling instructions

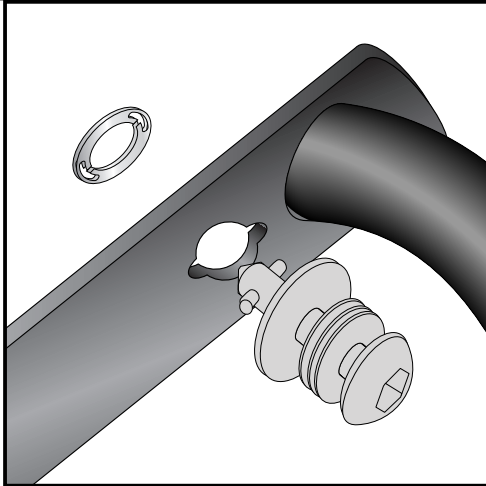

3

Fastening of Lock it screws:

The Lock it screws will be fixed at the carriers left and right with lock washers.

You have to do it only once - the screws and lock washers remain at the carriers.

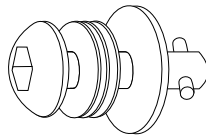

6x

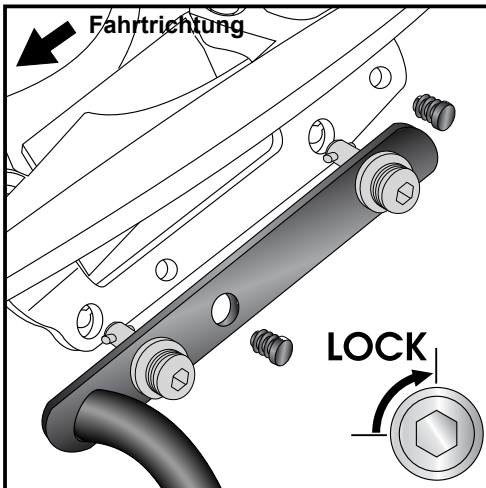

4

Fastening of the rear guard top:

The rear guard will now be fixed to the adapter with Lock it -screws

Stick the plastic caps into the free borings.

The borings will be used when mounting the optional alurack.

Attention !

Don't overturn the Lock it screw !

Rotate slowly one quarter of a turn until screw engages.



4x

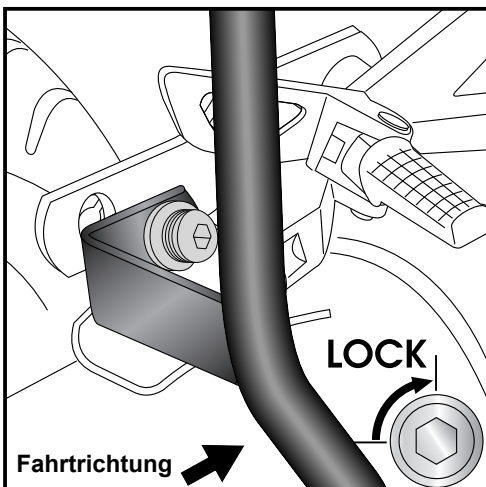

5

Fastening of the rear guard :

The rear guard will now be fixed to the adapter with Lock it -screws

Attention !

Don't overturn the Lock it screw !

Rotate slowly one quarter of a turn until screw engages.

Luggage ideas.

3