



Motorschutzplatte

HONDA XL 700 V Transalp

Artikel-Nr.: 810.952

Motorschutzplatte

HONDA XL 700 V Transalp

Artikel-Nr.: 3001.038.301

Montage

Der Bausatz umfaßt die folgenden Teile:

Stück	Bestellnr.	Bezeichnung	Stück	Bestellnr.	Bezeichnung
1	700008092	Motorschutzplatte	2	151.043	Aludistanzen Ø20xØ9x10mm
1	700008093	Halteadapter	1	151.116	Aludistanz Ø18xØ9x5mm
2	150.984	Gummierte Schellen Ø30	5	150.810	U-Scheiben Ø8,4
2	151.302	Senkscheiben Ø6,4	3	150.800	selbstsichernde Mutter M8
2	151.302	Senkscheiben Ø8,4	1x	330.301	Emblem Krauser Ø30mm
2	151.024	Senkinbusschrauben M6x20	1x	330.302	Emblem H&B Ø30mm
2	151.145	Senkinbusschrauben M8x30	4	275.002	Gummistopfen
1	151.379	Sechskantschraube M8x110			



Anzugsmomente des Motorradherstellers beachten!
Nach der Montage alle Verschraubungen auf festen Sitz kontrollieren!
Bitte beachten Sie unsere beigefügten Serviceinformationen.



Hepco & Becker GmbH
An der Steinmauer 6
D-66955 Pirmasens
Tel.: 06331 - 1453 - 100
Fax: 06331 - 1453 - 120
eMail: vertrieb@hepco-becker.de
www.hepco-becker.de



Krauser GmbH
An der Steinmauer 6
D-66955 Pirmasens
Tel.: 06331 - 1453 - 250
Fax: 06331 - 1453 - 260
eMail: vertrieb@krauser.de
www.krauser.de



Motorschutzplatte

HONDA XL 700 V Transalp

Artikel-Nr.: 810.952

Motorschutzplatte

HONDA XL 700 V Transalp

Artikel-Nr.: 3001.038.301

Montage

Vorbereitung:

Original Kunststoffmotorschutz demontieren - diese entfällt.
Das obere Verkleidungsteil wieder mit den Original Schrauben befestigen.
Zwischen Verkleidung und Rahmen links und rechts die Aludistanzen ① Ø20xØ9x10 fügen.

2x

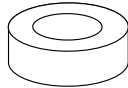

Montage des Halteadapters: ②

Die untere Schraube der Motor-aufhängung demontieren (entfällt).
Den Halter von vorne einschieben und mit der Sechskantschraube M8x110 sowie U-Scheiben Ø8,4 und selbstsichernder Mutter M8 verschrauben.
Links zwischen Halter und Hupenhalter die U-Scheibe Ø8,4 fügen.
Rechts zwischen Halteadapter und Motorhalter die Aludistanz Ø18xØ9x5mm fügen.
Noch nicht ganz festziehen.

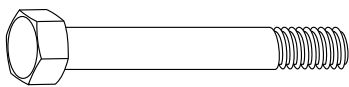

1x

3x

1x

1x



1

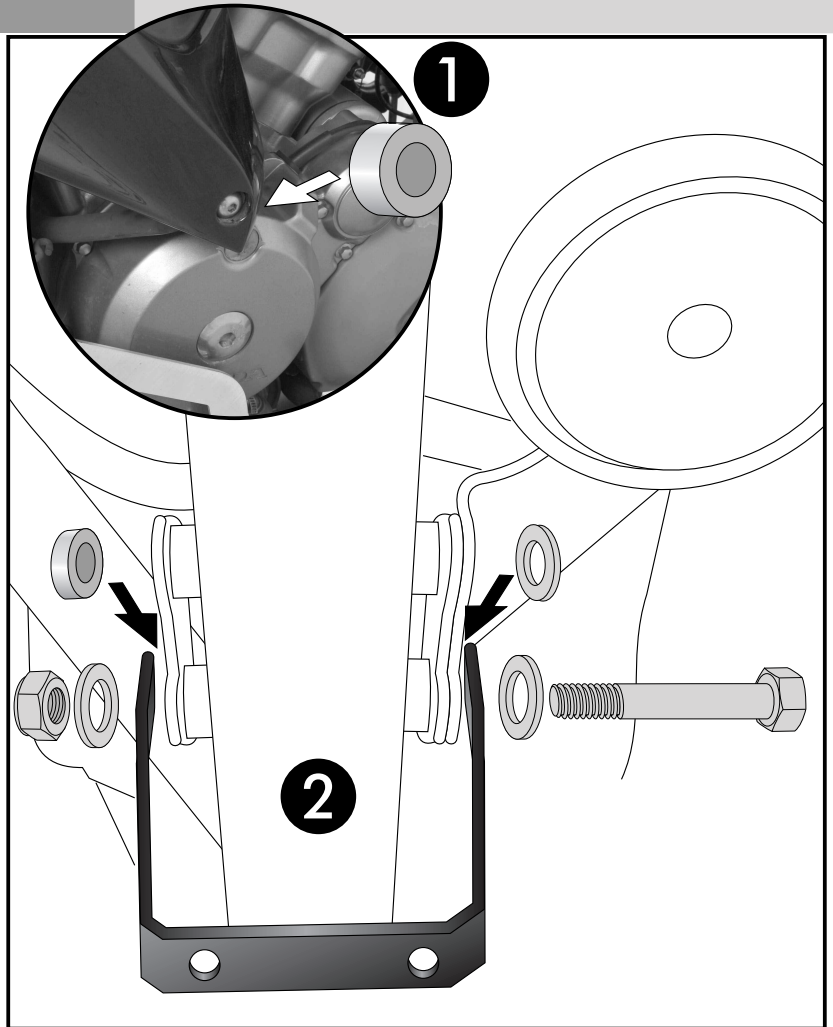

Die Gummipuffer werden von oben nach unten in die dafür vorgesehenen Bohrungen der Alu-Motorschutzplatte gesteckt.

2

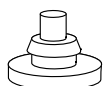
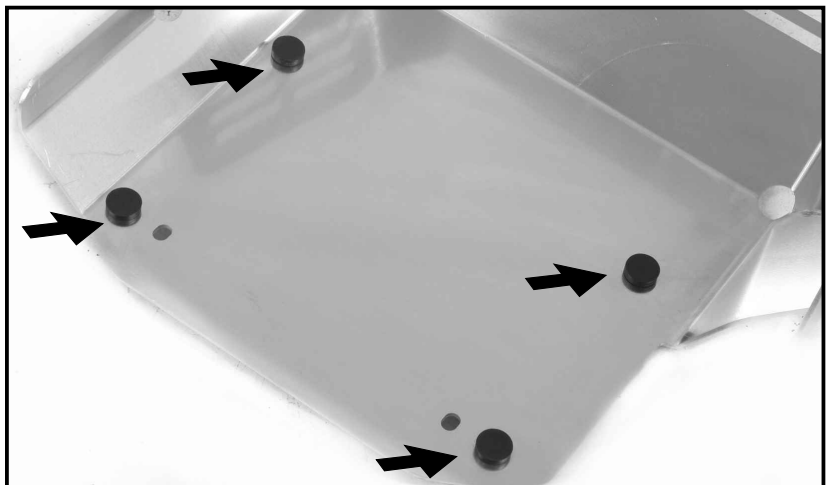

4x



Motorschutzplatte

HONDA XL 700 V Transalp

Artikel-Nr.: 810.952

Motorschutzplatte

HONDA XL 700 V Transalp

Artikel-Nr.: 3001.038.301

Montage

Montage der Schellen hinten links und rechts:

Am hinteren unteren Rahmen die gummierten Schellen über dem Rahmen positionieren.

3

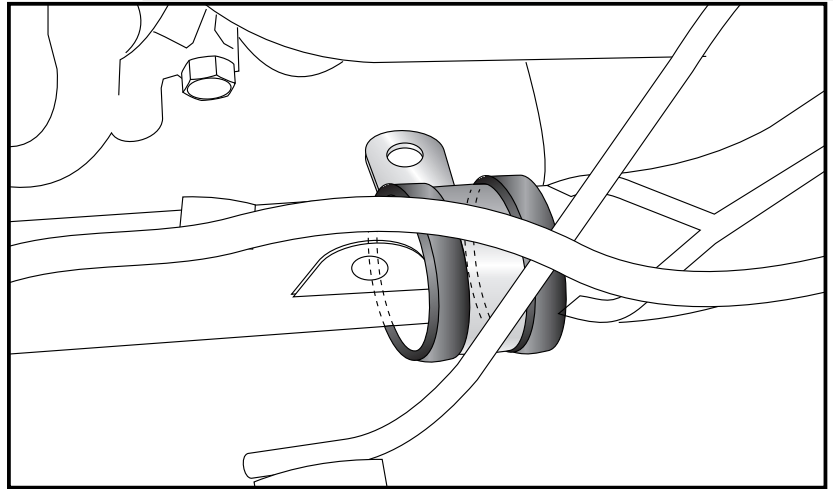

Montage der Motorschutzplatte vorne:

Den Unterfahrschutz an dem zuvor montierten Halter mit den Senkinbusschrauben M6x20 sowie Senkscheiben Ø6,4 anschrauben.

4

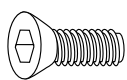
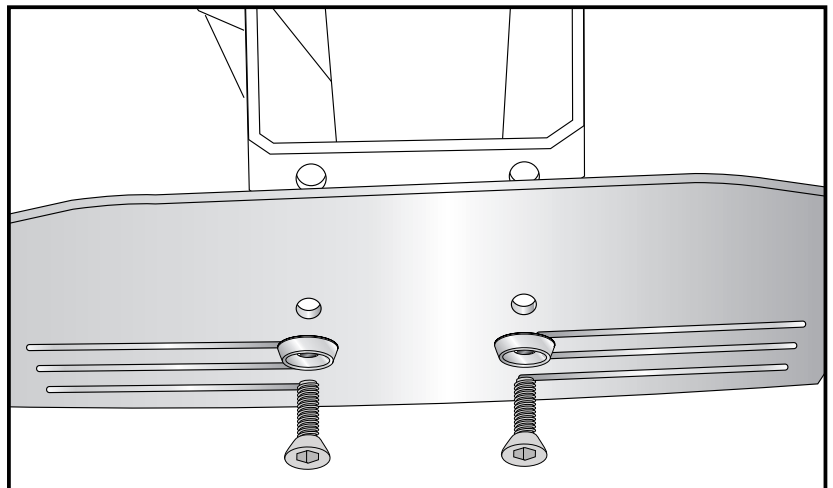

2x



2x

Montage der Motorschutzplatte hinten links und rechts:

An den zuvor montierten Schellen mit den Senkinbusschrauben M8x30 sowie den Senkscheiben Ø8,4. Von oben mit den selbstsichernden Muttern M8 sowie der U-Scheibe Ø8,4 verschrauben. Nun den vorderen Halteadapter festziehen.

5

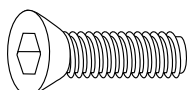
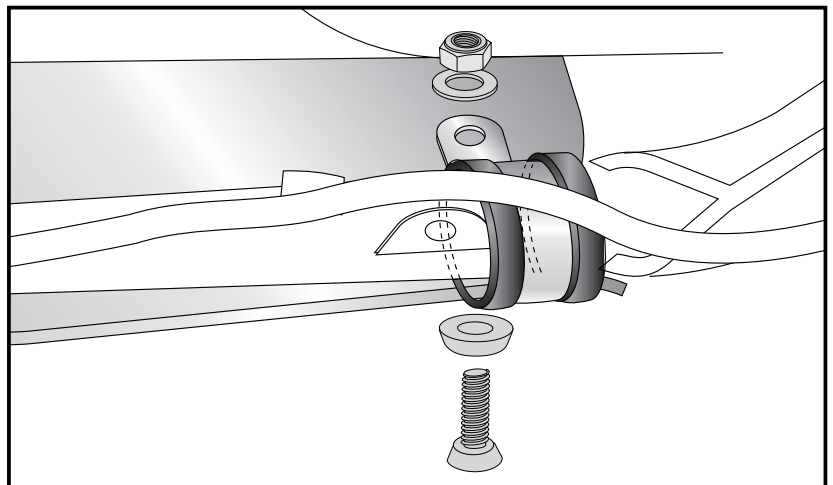

2x



2x



2x



2x



Skid plate

HONDA XL 700 V Transalp

Item - No.: 810.952

Skid plate

HONDA XL 700 V Transalp

Item - No.: 3001.038.301

Assembling instructions

The kit includes the following parts:

Quant	item no.	description	Quant	item no.	description
1	700008092	skid plate	2	151.043	alu spacer Ø20xØ9x10mm
1	700008093	adapter	1	151.116	alu spacer Ø18xØ9x5mm
2	150.984	rubberized clamp Ø30	5	150.810	washer Ø8,4
2	151.302	countersunk washer Ø6,4	3	150.800	self lock nut M8
2	151.302	countersunk washer Ø8,4	1x	330.301	emblem Krauser Ø30mm
2	151.024	countersunk head screw M6x20	1x	330.302	emblem H&B Ø30mm
2	151.145	countersunk head screw M8x30	4	275.002	rubber
1	151.379	hexagon bolt M8x110			



Control all screw connections after the assembling for tightness!
Please notice our enclosed service information.



Hepco & Becker GmbH
An der Steinmauer 6
D-66955 Pirmasens
Germany
Tel.: +49 6331 - 1453 - 100
Fax: +49 6331 - 1453 - 120
eMail: vertrieb@hepco-becker.de
www.hepco-becker.de



Krauser GmbH
An der Steinmauer 6
D-66955 Pirmasens
Germany
Tel.: +49 6331 - 1453 - 250
Fax: +49 06331 - 1453 - 260
eMail: vertrieb@krauser.de
www.krauser.de



Skid plate

HONDA XL 700 V Transalp

Item - No.: 810.952

Skid plate

HONDA XL 700 V Transalp

Item - No.: 3001.038.301

Assembling instructions

Preparing:

Dismantle original engine protection, it is obsolete.

Fix the upper fairing again with the original screws, but before sandwich alu spacer $\text{Ø}20 \times \text{Ø}9 \times 10$ between frame and fairing. ①

2x

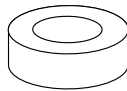

Fastening of the adapter front: ②

Dismantle the bottom screw of the engine bolting - it is obsolete.

Push the holder from the front and fix it with hexagon bolt M8x110 with washer $\text{Ø}8,4$ and self lock nut M8.

Sandwich washer $\text{Ø}8,4$ on the left side between the adapter and the horn bracket. Sandwich alu spacer $\text{Ø}18 \times \text{Ø}9 \times 5\text{mm}$ on the right side between the adapter and the engine holder. Do not tighten yet.

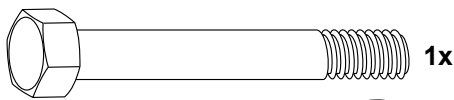

1x

1x



1x



3x

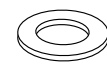

1

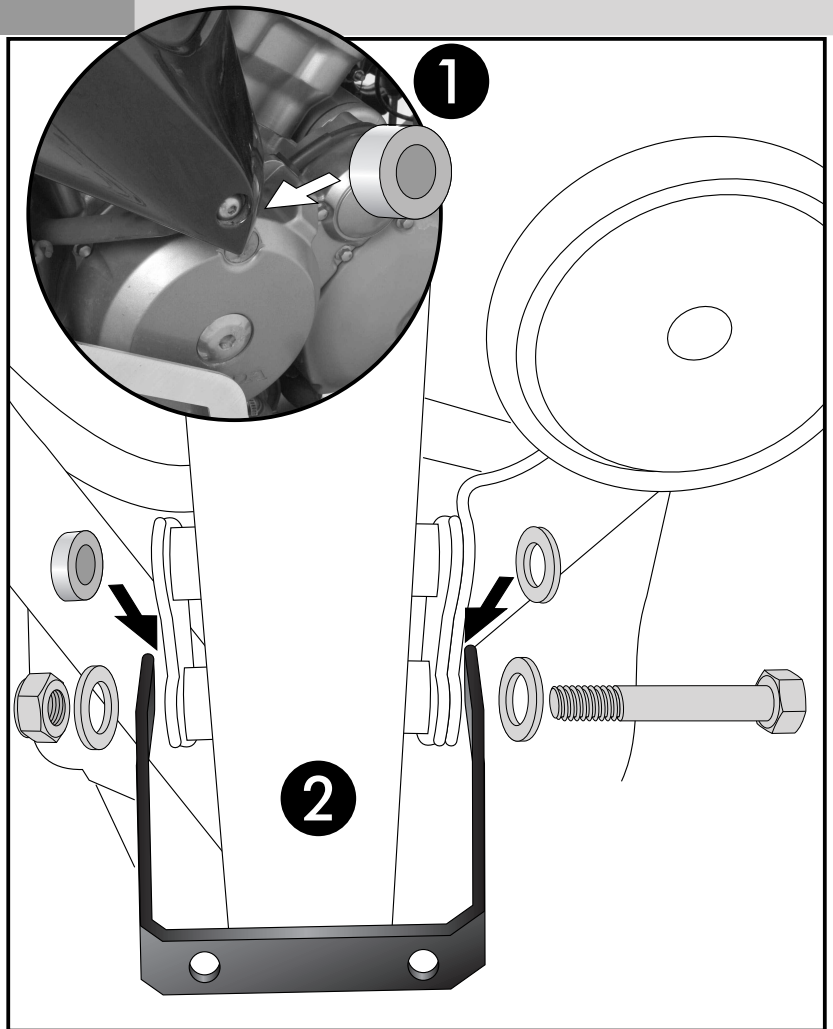

The rubbers are placed from top to bottom in the holes at the aluminum skid plate.

2

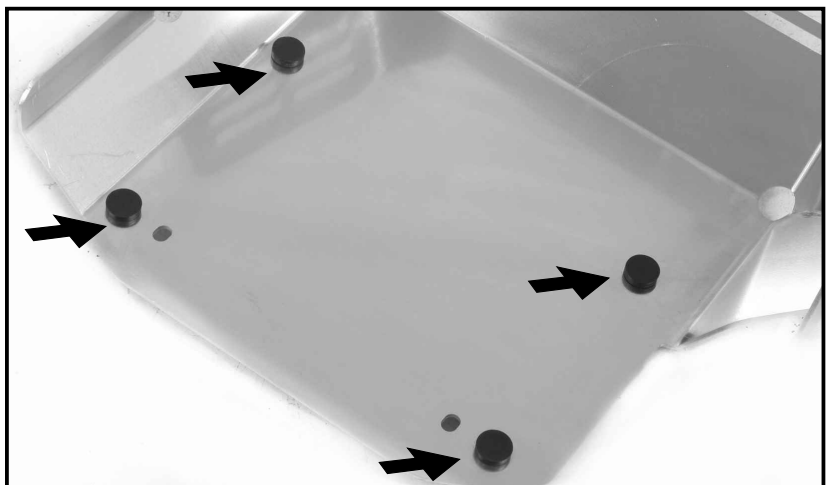

4x



Skid plate

HONDA XL 700 V Transalp

Item - No.: 810.952

Skid plate

HONDA XL 700 V Transalp

Item - No.: 3001.038.301

Assembling instructions

Fastening of the rubberized clamp
rear left + right:
at the rear bottom frame.

3

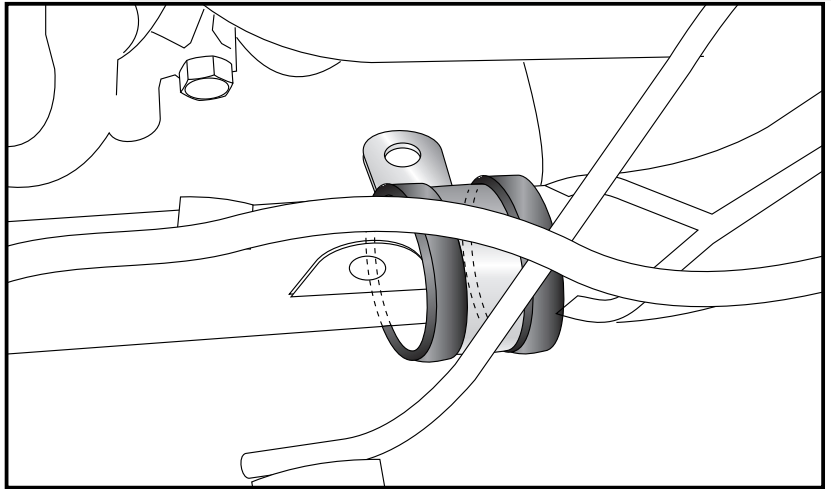

Fastening of the skid plate front:
at the adapter, mounted in step 1.
Use countersunk head screw M6x20 and
countersunk washer Ø6,4.

4

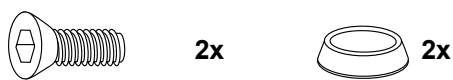
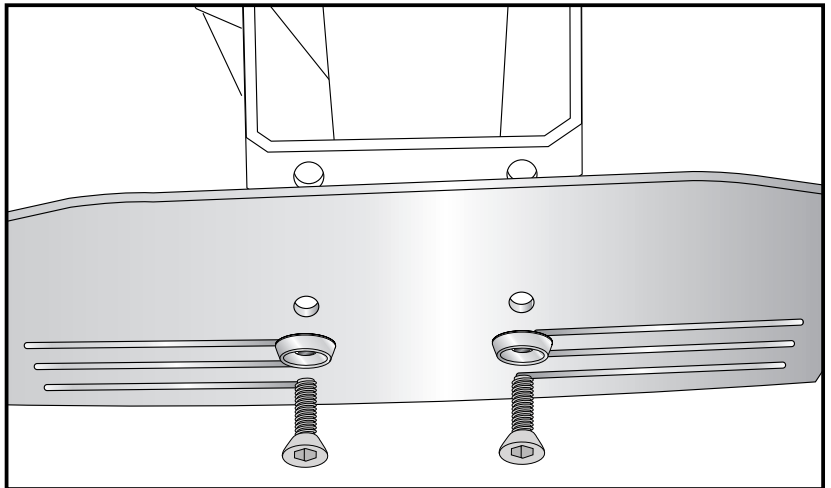

Fastening of the skid plate rear left + right:
at the clamps, mounted in step 3.
Fix the protection plate with countersunk
head screws M8x30 and countersunk
washers Ø8,4. From top screw with
self-locking nuts M8 and washer Ø 8,4.
Now screw on all screws to the torque
specific.

5

