

**THIS SHEET INCLUDES FITTING INSTRUCTIONS FOR THE FOLLOWING PARTS:**

Secondary Alternator Cover Part No. EC-ER6-2006-1-GBR / Secondary Clutch Cover Part No. EC-ER6-2006-2-GBR /  
Secondary Pulse Cover Part No. EC-ER6-2006-3-GBR /  
Paddock Stand Bobbin Set Part No. BA12-10-GBR-SET (Models 2006-2014) / Bobbin Set Part No. BA12-8-GBR-SET (Models 2015-2023) /  
Lower Chain Guard Part No. CGA09-GBR



**SECONDARY ALTERNATOR COVER**  
**PART NO. EC-ER6-2006-1-GBR**

- 1 Remove lower fairing.
- 2 Remove 4 existing bolts from the Alternator cover, shown as position Bolt 1, 2, 3 & 4. Note cable bracket at position 4.
- 3 Place the Secondary Clutch Cover over the stock cover.
- 4 Assemble 4 replacement bolts loosely in the correct position as shown. *Note: Must use thread lock.* Bolt 3 is M6 X 50HHF. Ensure that the cable bracket is aligned correctly at position 4.
- 5 Tighten bolts to a Torque of 11Nm as per Manufacturer's recommendations. **DO NOT OVERTIGHTEN.**

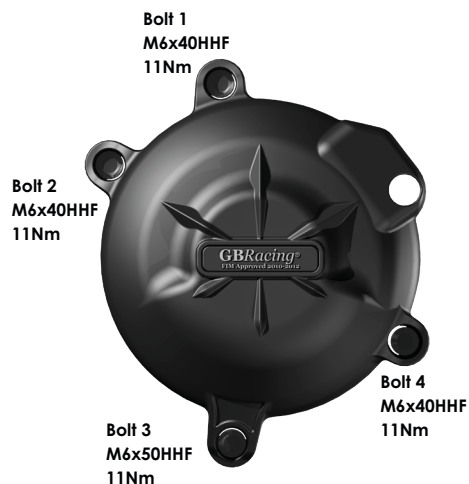
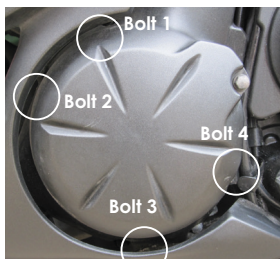

**SECONDARY CLUTCH COVER**  
**PART NO. EC-ER6-2006-2-GBR**

- 1 Remove lower fairing.
- 2 Remove 3 existing bolts from the Clutch cover, shown as position Bolt 1, 2 & 3.
- 3 Place the Secondary Clutch Cover over the stock cover.
- 4 Assemble 3 replacement bolts loosely in the correct position as shown. **Note: Must use thread lock**
- 5 Tighten bolts to a Torque of 11Nm as per Manufacturer's recommendations. **DO NOT OVERTIGHTEN.**

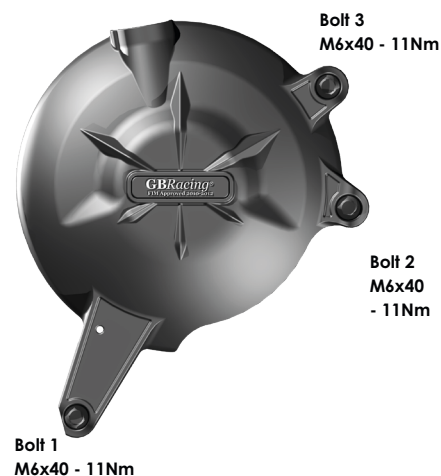
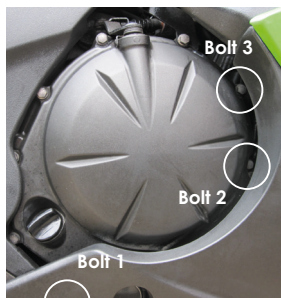

**SECONDARY PULSE COVER**  
**PART NO. EC-ER6-2006-3-GBR**

- 1 Remove lower fairing.
- 2 Remove 3 existing bolts from the Pulse cover, shown as position Bolt 1, 2 & 3.
- 3 Place the Secondary Pulse Cover over the stock cover.
- 4 Assemble 3 replacement bolts loosely in the correct position as shown. **Note: Must use thread lock**
- 5 Tighten bolts to a Torque of 11Nm as per Manufacturer's recommendations. **DO NOT OVERTIGHTEN.**

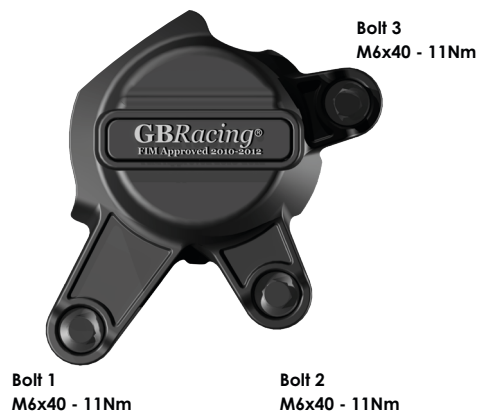
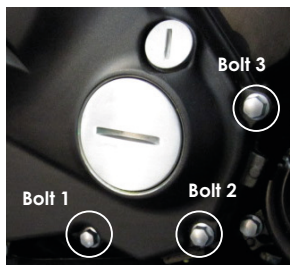

**FOR MODELS 2006-2014:**

**PADDOCK STAND / BOBBIN SET - PART NO. BA12-10-GBR-SET**

- 1 Assemble the M10 Stainless Steel bolt through the moulded bobbin and the Black Anodised Bush.
- 2 Tighten bolts to the swing arm boss, 8 N/m.

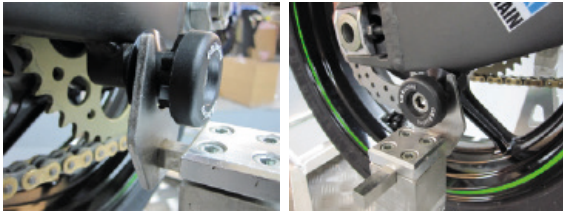

M10 x 1.25P x 40mm - 8 Nm



1 x Moulded Paddock Stand / Bobbin

**FOR MODELS 2015-2023:**

**PADDOCK STAND / BOBBIN SET - PART NO. BA12-8-GBR-SET**

- 1 Assemble M8 x 40mm Bolt through the moulded bobbin.
- 2 Tighten bolts to swing arm boss, 8 Nm.  
DO NOT OVERTIGHTEN



1 x M8 x 40 Bolt



1 x Moulded Paddock Stand / Bobbin

**LOWER CHAIN GUARD  
PART NO. CGA09-GBR**

- 1 Assemble 2 off M6 x 20mm bolts and washers through the moulded lower chain guard into the Black Anodised aluminium mounting block CGA09-2.
- 2 Position the assembly underneath the swing arm, closing the gap to the rear sprocket. Note : There should be a 5mm minimum gap from the bike chain to the lower chain guard.
- 3 Mark the position of the Black Anodised block, relative to the swing arm.
- 4 Disassemble the assembly, leaving the block to be replaced into the correct position.  
Mark the C/Sunk fixing hole positions on the underside of the swing arm.
- 5 Drill & Tap the marked holes , M6 - (Drill 5mm Dia. for tapping)
- 6 Re-assemble the lower chain guard to the fixed block.



2 x C/Sunk Bolts  
M6x10 - 10Nm

2 x Bolts &  
Washers  
M6x20 - 10Nm

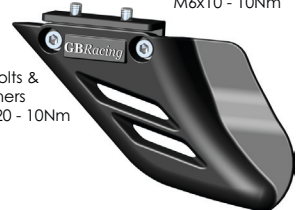

[www.GBRacing.eu](http://www.GBRacing.eu)

**Protection Bundle: CP-ER6-2006-CS-GBR**

EC-ER6-2006-1-GBR, EC-ER6-2006-2-GBR, EC-ER6-2006-3-GBR, CGA09-GBR, BA12-10-GBR-SET

**Engine Cover Set: EC-ER6-2006-SET-GBR**

EC-ER6-2006-1-GBR, EC-ER6-2006-2-GBR, EC-ER6-2006-3-GBR