

THIS SHEET INCLUDES FITTING INSTRUCTIONS FOR THE FOLLOWING PARTS:

Secondary Alternator Cover Part No. EC-ZX-25R-2020-1-GBR /

Secondary Clutch Cover Part No. EC-ZX-25R-2020-2-GBR /

Secondary Pulse Cover Part No. EC-ZX-25R-2020-3-GBR /

Bullet Frame Sliders Part No. FS-ZX-25R-2020-LHS-S & FS-ZX-25R-2020-RHS-S

SECONDARY ALTERNATOR COVER
PART NO. EC-ZX-25R-2020-1-GBR

1. Remove lower fairing panel.
2. Remove 4 existing bolts from the stock Alternator cover, shown as position Bolt 1, 2, 3 & 4.
3. Place the Secondary Alternator Cover over the stock cover.
4. Assemble 4 replacement bolts loosely in the correct position as shown.
5. Tighten bolts to a Torque of 11Nm as per manufacturer's recommendations. **DO NOT OVERTIGHTEN.**
6. Re-fit lower fairing panel.

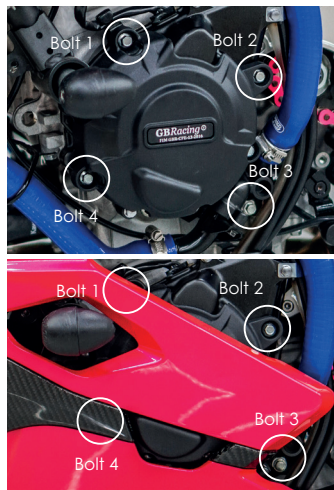

SECONDARY CLUTCH COVER
PART NO. EC-ZX-25R-2020-2-GBR

1. Remove lower fairing panel.
2. Remove 4 existing bolts from the Clutch cover, shown as position Bolt 1, 2, 3 & 4.
3. Place the Secondary Clutch Cover over the stock cover.
4. Assemble 4 replacement bolts loosely in the correct position as shown.
5. Tighten bolts to a Torque of 11Nm as per manufacturer's recommendations. **DO NOT OVERTIGHTEN.**
6. Re-fit lower fairing panel.

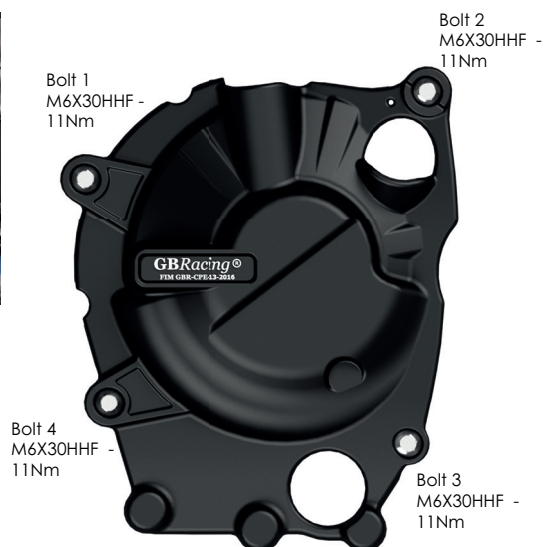
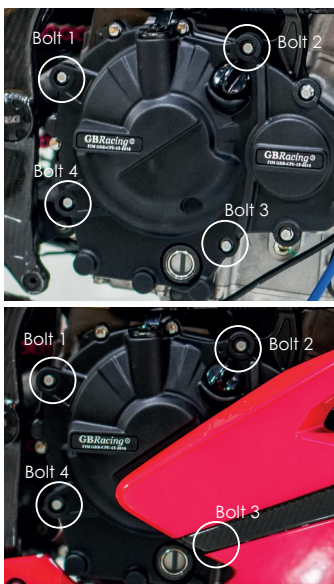

SECONDARY PULSE COVER
PART NO. EC-ZX-25R-2020-3-GBR

1. Remove lower fairing panel.
2. Remove 3 existing bolts from the Pulse cover, shown as position Bolt 1, 2 & 3.
3. Place the Secondary Pulse Cover over the stock cover.
4. Assemble 3 replacement bolts loosely in the correct position as shown.
5. Tighten bolts to a Torque of 11Nm as per manufacturer's recommendations.
6. Re-fit lower fairing panel.

DO NOT OVERTIGHTEN.

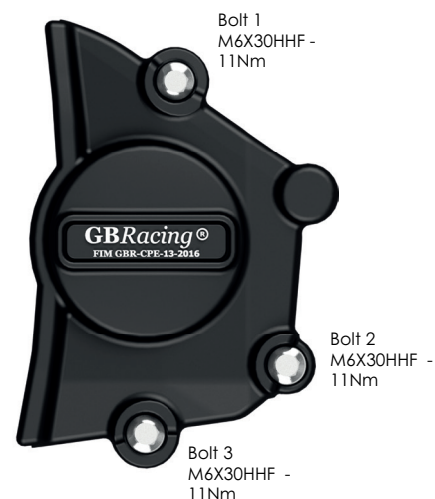
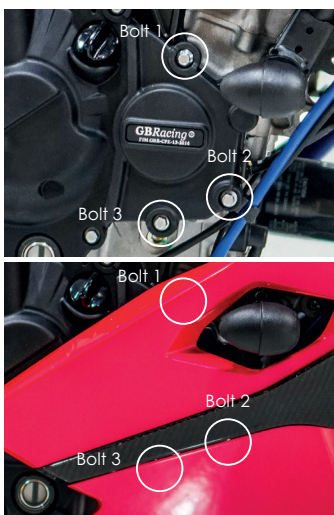

BULLET FRAME SLIDER SET - PART NO. FS-ZX-25R-2020-S:

BULLET FRAME SLIDER - LEFT HAND SIDE - STREET
PART NO. FS-ZX-25R-2020-LHS-S

- 1 Remove upper engine mounting bolt, located through the fairing opening.
- 2 Assemble bolt through the aluminium bush into correct position.
- 3 Tighten to 40NM torque.
- 4 Slide bullet moulding onto aluminium bush.
- 5 Screw M6 bolt into front of bullet moulding hand tight.



BULLET FRAME SLIDER - RIGHT HAND SIDE - STREET
PART NO. FS-ZX-25R-2020-RHS-S

- 1 Remove upper engine mounting bolt, located through the fairing opening.
- 2 Assemble bolt through the aluminium bush into correct position.
- 3 Tighten to 40NM torque.
- 4 Slide bullet moulding onto aluminium bush.
- 5 Screw M6 bolt into front of bullet moulding hand tight.

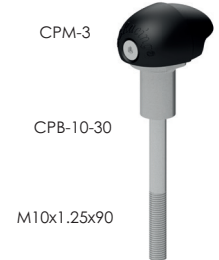

ALSO FITS THIS MODEL

UNIVERSAL LOWER CHAIN GUARD ASSEMBLY	CGA18-GBR-SET
PADDOCK STAND / BOBBIN KIT	BA12-8-GBR-SET
REPLACEMENT MOULDED BULLET SLIDER	CPM-3
GOPRO CAMERA MOUNT	CPM-3-GP
BRAKE LEVER GUARD, <i>A160 MOULDED REPLACEMENT PART ONLY</i>	BLG-A160
CLUTCH LEVER GUARD, <i>A160 MOULDED REPLACEMENT PART ONLY</i>	CLG-A160
BRAKE LEVER GUARD	BLG-M8-S5-B5-R6-A160-GBR
CLUTCH LEVER GUARD	CLG-M8-S5-B5-R6-A160-GBR